

# 1995 Ferrari 355 Spider

VIN: ZFFPR48B000102248

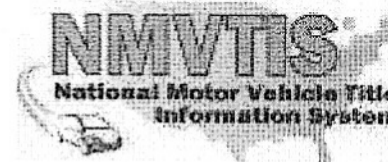





Scan or visit [verify.add123.com](http://verify.add123.com) to verify

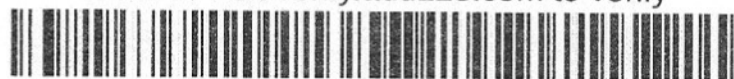

Verification Code: RLWA6WP

## National Title History / Title Pointer (NMVTIS)

Retrieved On: Mon August 26, 2024 03:08:59 PM EDT

Reference ID: 1995 Ferrari 355 Spider

### Vehicle Information

VIN: ZFFPR48B000102248

### Vehicle Brands

Gray Market applied by CALIFORNIA on 20010625

Vehicle was manufactured for use outside the United States and has been brought into the United States. The vehicle is in compliance with applicable federal standards.

### Title Information

Title: California 07/19/2001 000025535 Miles

### Junk/Salvage/Insurance Reporting

No Junk/Salvage Reports

No Insurance Reports

#### Explanatory Note:

If this VIN has a record in the **Junk/Salvage or Insurance information** then the business that submitted the VIN to NMVTIS deemed the vehicle to be either a *junk, salvage, or in the case of an insurer, a total loss*. The information in the **DISPOSITION** field in the Junk/Salvage section denotes what has happened to the VIN (i.e., vehicle) since it came into the possession of the business.

Brand, Title and Junk/Salvage Insurance Reporting information provided from the National Motor Vehicle Title Information System (NMVTIS).

View the NMVTIS disclaimer at <https://www.add123.com/nmvtisdisclaimer>

Auto Data Direct is an Approved NMVTIS Data Provider.

## Lien / Theft Data

Retrieved On: Mon August 26, 2024 03:09:00 PM EDT

### Vehicle Information

VIN: ZFFPR48B000102248

### Theft Information

No theft information found

### Liens

No lien information found

Lien data does not include information on all motor vehicles in the United States because not all lienholders provide information to the source of this lien data.

Lien / Theft data is restricted to business use only and cannot be distributed to the general consumer.







## Vehicle History Report™

VIN: ZFFPR48B000102248	<div style="display: flex; align-items: center; margin-bottom: 10px;"> <input checked="" style="margin-right: 5px;" type="checkbox"/> <span>No accidents or damage reported to CARFAX</span> </div> <div style="display: flex; align-items: center; margin-bottom: 10px;"> <span style="font-size: 2em; margin-right: 5px;">✂</span> <span>1 Service history record</span> </div> <div style="display: flex; align-items: center; margin-bottom: 10px;"> <span style="font-size: 2em; margin-right: 5px;">📁</span> <span>16 Detailed records available</span> </div> <div style="display: flex; align-items: center;"> <span style="font-size: 2em; margin-right: 5px;">📊</span> <span>28,628 Last reported odometer reading</span> </div>
------------------------	--



This CARFAX Vehicle History Report is based only on information supplied to CARFAX and available as of 8/21/24 at 2:50:00 PM (CDT). Other information about this vehicle, including problems, may not have been reported to CARFAX. Use this report as one important tool, along with a vehicle inspection and test drive, to make a better decision about your next used car.

 <b>Additional History</b> Not all accidents / issues are reported to CARFAX	<b>Summary</b>
<b>Total Loss</b> No total loss reported to CARFAX.	<input checked="" type="checkbox"/> No Issues Reported
<b>Structural Damage</b> No structural damage reported to CARFAX.	<input checked="" type="checkbox"/> No Issues Reported
<b>Airbag Deployment</b> No airbag deployment reported to CARFAX.	<input checked="" type="checkbox"/> No Issues Reported
<b>Odometer Check</b> No indication of an odometer rollback.	<input checked="" type="checkbox"/> No Issues Indicated
<b>Accident / Damage</b> No accidents or damage reported to CARFAX.	<input checked="" type="checkbox"/> No Issues Reported
<b>Manufacturer Recall</b> Check with an authorized dealer for any open recalls.	<b>Ask Your Dealer</b>
<b>Basic Warranty</b> No data reported to CARFAX.	No Data Reported

 <b>Title History</b>	<b>Summary</b>
<b>Damage Brands</b> Salvage   Junk   Rebuilt   Fire   Flood   Hail   Lemon	No Problem

^ Back To Top



**Odometer Brands**

Not Actual Mileage | Exceeds Mechanical Limits

No Problem

**CARFAX Detailed History**

Date	Mileage	Source	Comments
01/03/2001		US Dept of Transportation Long Beach, CA	Vehicle imported to United States
02/28/2001		US Dept of Transportation Long Beach, CA	Vehicle declared to meet US highway safety specifications Bond released
03/02/2001	25,201	California Inspection Station	Passed emissions inspection
03/24/2001	25,535	California Motor Vehicle Dept. Sonoma, CA	Odometer reading reported
06/25/2001		California Motor Vehicle Dept. Sonoma, CA	Title issued or updated Not built to US standards
03/18/2003	26,546	Service Facility Santa Rosa, CA	 Vehicle serviced
03/18/2003		California Inspection Station Santa Rosa, CA	Passed emissions inspection
03/10/2005	27,041	California Inspection Station	Passed emissions inspection
03/20/2008	27,445	California Inspection Station	Passed emissions inspection
03/23/2011	27,784	California Inspection Station San Rafael, CA	Passed emissions inspection
03/15/2013	28,197	California Inspection Station Sonoma, CA	Passed emissions inspection
02/25/2015	28,312	California Inspection Station Sonoma, CA	Passed emissions inspection

[^ Back To Top](#)



02/16/2017	28,456	California Inspection Station Sonoma, CA	<b>Failed emissions inspection</b> Passed emissions inspection
04/06/2021		California Inspection Station Sonoma, CA	<b>Passed emissions inspection</b>
12/04/2023	28,614	California Inspection Station Sonoma, CA	<b>Failed emissions inspection</b>
12/05/2023	28,628	California Inspection Station Sonoma, CA	<b>Passed emissions inspection</b>

Have Questions? Please visit our Help Center at [www.carfax.com](http://www.carfax.com).



### Glossary

**Built to Non U.S. Standards**

Vehicle previously registered or titled outside of the U.S. and may not comply with U.S. safety and emissions standards.

**Failed Emissions Inspection**

The emissions check performed during a vehicle inspection indicated the vehicle was emitting more than allowable emissions standards and/or had missing or modified parts. Repeated failed emissions records can indicate engine problems and CARFAX recommends you have the vehicle inspected.

**Title Issued**

A state issues a title to provide a vehicle owner with proof of ownership. Each title has a unique number. Each title or registration record on a CARFAX report does not necessarily indicate a change in ownership. In Canada, a registration and bill of sale are used as proof of ownership.

Follow Us:



[facebook.com/CARFAX](https://facebook.com/CARFAX)



[@CARFAXinc](https://twitter.com/CARFAXinc)



About CARFAX

CARFAX DEPENDS ON ITS SOURCES FOR THE ACCURACY AND RELIABILITY OF ITS INFORMATION. THEREFORE, NO RESPONSIBILITY IS ASSUMED BY CARFAX OR ITS AGENTS FOR ERRORS OR OMISSIONS IN THIS REPORT. CARFAX FURTHER EXPRESSLY DISCLAIMS ALL WARRANTIES, EXPRESS OR IMPLIED, INCLUDING ANY IMPLIED WARRANTIES OF MERCHANTABILITY OR FITNESS FOR A PARTICULAR PURPOSE.

© 2024 CARFAX, Inc., part of S&P Global. All rights reserved.  
8/21/24 2:50:00 PM (CDT)

[^ Back To Top](#)



liability for this vehicle may not be released if you submit illegible or incomplete information.

IT YOUR CHARACTERS IN CAPITAL LETTERS USING BLACK OR BLUE INK-READ INSTRUCTIONS ON REVERSE SIDE.

A B C D E F G H I J K L M N O P Q R S T U V W X Y Z 0 1 2 3 4 5 6 7 8 9

DMV MICROGRAPHICS USE ONLY

NOTICE OF RELEASE OF LIABILITY  
MAIL THIS FORM TO DMV

A. BUYER'S TRUE FULL NAME (LAST) (FIRST) (MIDDLE) B. IF DEALER, CHECK BELOW

C. BUYER'S ADDRESS

D. ODOMETER READING

E. CITY STATE ZIP CODE F. DATE OF SALE

G. SELLER'S TRUE FULL NAME (LAST) (FIRST) (MIDDLE)

H. SELLER'S ADDRESS

I. SELLING PRICE

J. CITY STATE ZIP CODE K. SELLER'S SIGNATURE

VEHICLE ID NUMBER: ZFFPR48B000102248 YR MODEL MAKE: 1995 FERRA PLATE NUMBER: 4SYF939

REG. 138A (REV. 11/97)

DO NOT DETACH UNTIL SOLD

STATE OF CALIFORNIA

CERTIFICATE OF TITLE

176010709K3

AUTOMOBILE

\*\*\* NON USA \*\*\*

VEHICLE ID NUMBER  
ZFFPR48B000102248

YR MODEL MAKE  
1995 FERRA

PLATE NUMBER  
4SYF939

BODY TYPE MODEL  
CV

UNLADEN AX WEIGHT FUEL TRANSFER DATE FEES PAID  
G \$776

REGISTRATION EXPIRATION DATE  
03/26/2002

YR 1ST SOLD CLASS YR MO EQUIPMT/TRUST NUMBER  
RE 2000 GU

ISSUE DATE  
07/19/01

MOTORCYCLE ENGINE NUMBER

ODOMETER DATE ODOMETER READING  
03/24/2001 25535 MI  
ACTUAL MILEAGE

SONOMA CA 95476

I certify under penalty of perjury under the laws of the State of California, that THE SIGNATURE(S) BELOW RELEASES INTEREST IN THE VEHICLE.

1a. DATE SIGNATURE OF REGISTERED OWNER

1b. DATE SIGNATURE OF REGISTERED OWNER

Federal and State law requires that you state the mileage upon transfer of ownership. Failure to complete or providing a false statement may result in fines and/or imprisonment.

The odometer now reads (no tenths), miles and to the best of my knowledge reflects the actual mileage unless one of the following statements is checked.

WARNING  Odometer reading is not the actual mileage.  Mileage exceeds the odometer mechanical limits.

I certify under penalty of perjury under the laws of the State of California that the foregoing is true and correct.

DATE	TRANSFEROR/SELLER SIGNATURE(S)	DATE	TRANSFeree/BUYER SIGNATURE(S)
	X		X
PRINTED NAME OF AGENT SIGNING FOR A COMPANY		PRINTED NAME OF AGENT SIGNING FOR A COMPANY	

IMPORTANT READ CAREFULLY

Any change of Lienholder (holder of security interest) must be reported to the Department of Motor Vehicles within 10 days.

LIENHOLDER(S)

2. X Signature releases interest in vehicle. (Company names must be countersigned)  
Release Date

CA 55946904

017883

REG. 17.30 (REV. 2/98)

KEEP IN A SAFE PLACE - VOID IF ALTERED







5 N° A023578VRO70695

TARGA

AG800YG

6 N° A023578VRO70695

TARGA

AG800

1 c

Ministero dei Trasporti  
e della Navigazione  
Motorizzazione Civile

AG800YG

IL PRESENTE TAGLIANDO VA STACCATO  
LUNGO LA LINEA PERFORATA E TENUTO A  
BORDO DEL VEICOLO.

È NECESSARIO ESPORLO IN CASO DI  
RESTRIZIONI AL TRAFFICO VEICOLARE  
PER ELEVATO TASSO DI INQUINAMENTO  
ATMOSFERICO.

ATTENZIONE - LA RICHIESTA DI ISCRIZIONE AL P.R.A. DEVE ESSERE PRESENTATA ENTRO 60 GIORNI DALLA DATA DI EMISSIONE DELLA CARTA DI CIRCOLAZIONE.

- (1) MASSA DEL VEICOLO IN ORDINE DI MARCIA (COMPRESO IL CONDUCENTE CONSIDERATO 70 KG E SENZA CARICO).
- (2) PER I VEICOLI PER TRASPORTO PROMISCUO DI PERSONE E COSE SONO AMMESSE TUTTE LE POSSIBILI COMBINAZIONI ENTRO LA PORTATA MASSIMA INDICATA PER LE SOLE COSE DEITRAENDO DALLA PORTATA LA MASSA DI 70 KG PER OGNI PERSONA TRASPORTATA ESCLUSO IL CONDUCENTE.
- (3) PER LE AUTOVETTURE E PER GLI AUTOVEICOLI PER TRASPORTO PROMISCUO LA MASSA RIMORCHIABILE DEVE ESSERE CONFERMATO CON VISITA E PROVA PER L'APPLICAZIONE DEL GANCIO DI TRAIINO.
- (4) QUANDO NON È INDICATO IL VALORE, IL CONTROLLO PER I VEICOLI USATI VA EFFETTUATO AL REGIME DI ROTAZIONE DEL MOTORE CORRISPONDENTE ALLA POTENZA MASSIMA.
- (5) PER LE MACCHINE AGRICOLE I DATI RIPORTATI SI RIFERISCONO ALLE MASSE CON ZAVORRA ANZICHE ALLE MASSE ECCEZIONALI.

IL DOCUMENTO DI CIRCOLAZIONE È VALIDO SOLO SE CONTIENE LE PAGINE NUMERATE DA 1 A 12.

GENERALITÀ E RESIDENZA DEL PROPRIETARIO

A/AG800YG /08.10.1997

\*\*\* TRASFERIMENTO DI PROPRIETA' \*\*\*  
PROPRIETARIO SRL FIN SERVICE

KSB9C1

RES. CERVIA

-RA-100 VIA C. SACCHETTI

\* \* \* \* \*  
\* \* \* \* \*  
\* \* \* \* \*  
\* \* \* \* \*  
\* \* \* \* \*

VERONA, 08.10.1997

AG.1014

La presente carta di circolazione non costituisce titolo di proprietà. La vendita del veicolo cui si riferisce è subordinata all'esibizione del certificato di proprietà, rilasciato dal P.R.A. ai sensi dell'art. 7, comma 2 della legge 9 luglio 1990 n. 187, oppure del foglio complementare rilasciato ai sensi dell'art. 6 del R.D. 29 luglio 1927 n. 1814.

A/AG800YG /22.09.2000

\*\*\* TRASFERIMENTO DI PROPRIETA' \*\*\*  
PROPRIETARIO SRL L'AUTOSALONE S.R.L.

RES. RUBIERA

-RE-54/A VIA EMILIA OVI

\* \* \* \* \*  
\* \* \* \* \*  
\* \* \* \* \*  
\* \* \* \* \*  
\* \* \* \* \*

REGGIO EMILIA, 22.09.2000

AC





Via Montecuccoli, 4  
41100 MODENA, Italy  
tel. (059) 21.76.61 fax (059) 21.76.37

Merce Ricevuta:-- Data 1/12/00 Ora 12:20

Nome Importatore e Indirizzo		Nome Esportatore e Indirizzo	
G & K Auto 3231 S. STANDARDS AVE SANTA ANA, CA 92705		SONOMA, CA 95470	
Compagnia di Navigazione <sup>CIELG</sup> <sub>DI ITALIA</sub>		Valuta per la Dogana \$62,061.	
Contenuto della Spedizione FERRARI F 355 SPIDER VIN ZFFPR488000102248			
<b>Coste e Emolumenti</b>			
Neleggio .....		8,800,000	
Assi Curazione .....		1,100,000	
Tasse .....		NIV	
		<b>Prezzo Totale</b>	
		L9,900,000	
Speciali Requeste di Maneggiamento			
			



Sede: 41100 Modena - Via Montecuccoli, 4 - Tel. (059) 217661 4 linee - C.F. 00901080366 - C.C.I.A.A. Modena 193468  
Telefax (059) 217637 - 248233

SPEDIZIONI INTERNAZIONALI - MARITTIME - TERRESTRI - AEREE - CONSULENZE SERVIZI INTERMODALI

**R I M E S S A   D O C U M E N T I**

li, 15 MARZO, 2001  
Ns.rif.: 011EXM0888  
5601/  
User LUCI

Spett.le  
FERRIAUTO SRL

P.LE RISORGIMENTO,1  
41100 MODENA

MO

Mittente  
FERRIAUTO SRL

P.LE RISORGIMENTO,1  
41100 MODENA

MO

Fatt.fornit. : FATT.77-72/AE  
del :

Destinatario

Resa :

S:

Nave

: CIELO D'ITALIA

del

: 02/12/2000

E

Pto.Imbarco :

SONOMA CA 95476 USA

Pto.Sbarco :

Id.container	Colli	Szty	Imballo	Descrizione merce	Peso Lordo
CPSU1607835	1	20BX	PZ	AUTOVETTURA FERRARI	1510,00
	1				1510,00

ALLEGATI ALLA PRESENTE VI RIMETTIAMO :

- N° 1 BOLLA DOGANALE N°10063 V DEL 29.11.00
- N° 1+1 VS.FATTURE N°72/AE E 77 VISTATE DOGANA
- N° 1 CERT,RADIAZIONE ORIGINALE IN RESTITUZIONE

Distinti Saluti  
EMILSPED SRL

COMUNITA EUROPEA  
01644910364

**3** 1 Dichiarazione EX

2 Speditore / Esportatore **FERRARI AUTO S.R.L.**

3 Formulari 4 Dist. di carico

5 Articoli **1** 6 Totale dei colli **1** 7 Numero di riferimento **012974R**

8 Destinatario **N.** 9 Nulla osta ai fini dei divieti economici e valutari  
**CIELO D'ITALIA** Il funzionario **Neri Alessandro Operatore Tributario**

10 Paese prima destinaz. 11 Paese di transazione

14 Dichiarante/Rappresentante **005721V** 15 Paese di spedizione / esportazione **ITALIA** 15 Cod. P. sped./esport. **005** 17 Cod. P. destinaz. **400**

**CARRARA EMILIO** 16 Paese di origine **ITALIA** 17 Paese di destinazione **USA**  
Spedizioniere Doganale

18 Identità e nazionalità del mezzo di trasporto alla partenza **436** 19 Ctr. **1** 20 Condizioni di consegna **EXW MODENA**

21 Identità e nazionalità del mezzo di trasporto attivo che attraversa la frontiera **436 005 15100000** 22 Moneta ed importo totale fatturato **1** 23 Tasso di cambio **1** 24 Natura della transazione **1**

25 Modo di trasporto alla frontiera **1** 26 Modo di trasporto interno **interno** 27 Luogo di carico **MODENA** 28 Dati finanziari e bancari

29 Ufficio di uscita **052109** 30 Localizzazione delle merci

31 Colli e designazione delle merci **1** Marche e numeri - N. contenitori - Quantità e natura **PEZZO 1** 32 Articolo **1 A N.** 33 Codice delle merci **87032490**

**AUTOVETTURA SUP. A 3000 C.C. USATA**  
**FERRARI 355 SPYDER con accessori**  
**TELAIO: ZFFPR48B000102248**

34 Cod. P. di origine **MO** 35 Massa lorda (kg) **1510**

37 REGIME **1000 1** 38 Massa netta (kg) **1510** 39 Contingenti

40 Dichiarazione sommaria / Documento precedente

41 Unità supplementari

44 Menzioni speciali/ Documenti presentati/ Certificati ed autorizzazioni **FATT. N. 72/AE LIT. 137.000.000**  
**77 14.000.000**  
**N.O. POLIZIA E DOC. P.R.A. A MATANCE**

46 Valore statistico **151500000**

47 Calcolo delle imposizioni	Tipo	Base imponibile	Aliquota	Importo	48 Dilazione di pagamento	49 Identificazione del deposito
	552	2	375	750	G	
	553	2	450	900	G	
	901	2	450	900	G	
Totale:				2550		

49 Identificazione del deposito  
**CONTO N. 0452F - A 93 N.2551**  
**DEL 29.11.00**  
**SCAD. 30.11.00**

\*NC\* FIRMA : **Neri Alessandro Operatore Tributario**

50 Obbligato principale **N.** Firma: **C UFFICIO DI PARTENZA 052109-Darsena Toscana**

51 Uffici di passaggio previsti (e paesi) rappresentato da: **Neri Alessandro Operatore Tributario**  
Luogo e data: **LIVORNO, 28-11-00**

52 Garanzia non valida per

D CONTROLLO DELL'UFFICIO DI PARTENZA **CONFORME AMMESSO**  
**Dichiarazione non verificata**

Risultato:  
Suggelli apposti: Numero:  
marche:  
Termine (data limite):  
Firma:

53 Ufficio di destinazione (e paese) **LIVORNO, 28-11-00**

54 Luogo e data:  
Firma e nome del dichiarante / rappresentante:  
**CARRARA EMILIO**  
Spedizioniere Doganale 005721V

Esemplare per lo speditore / esportatore

3

3



3 PAIC

ASIANIR IO...  
ATTESU ID...  
MAGGI...  
DE...  
VI...  
VI...



Data 06/12/2000

Rivenditore: Toni Auto  
Via Abetone Inf.41  
41053 Maranello

MO

Telefono: 0536/941131 Fax: 0536/942655

Email

FATTURA 52  
FERRI AUTO  
FERR 355 SPIDER

Articolo	Descrizione	U.m.	Quantità	Prezzo	Sconto	Importo
	SILENZIATORE DI SCARICO CPL	NR	1,00	2.000.000	0,00	2.000.000
	CATALIZZATORE COMPLETO SINIS	NR	1,00	1.500.000	0,00	1.500.000
	CATALIZZATORE COMPLETO DESTR	NR	1,00	1.500.000	0,00	1.500.000
	VALVOLA DI BY-PASS X GAS DI	NR	1,00	1.920.000	0,00	1.920.000
	DISCO FRIZIONE	NR	1,00	420.000	0,00	420.000
	TACHIMETRO ELETTRONICO	NR	1,00	640.000	0,00	640.000
	MANODOPERA PER LAVORI		1,00	400.000	0,00	400.000

Tasse: 0

Totale: Lit. **8.380.000**



AUTOMOBILE CLUB D'ITALIA



PUBBLICO REGISTRO AUTOMOBILISTICO  
A023 (53)

(art. 7L. 187/90)

TARGA

AG800YG

CERTIFICATO DI PROPRIETÀ

N. 00/A159388P

UFFICIO  
PROV. DI

MODENA

### A DATI del VEICOLO

TELAIO ZFFPR48B000102248

classe/uso AUTOVETTURA / PRIVATO TRASPORTO PERSONE	
fabbrica/tipo FERRARI SPA F 129 AD	data immatricolazione
dati fiscali	

### B DATI della INTESTAZIONE

numero  
precedenti intestazioni

numero  
intestatari

NOMINATIVO	<input type="checkbox"/>	PROPRIETARIO	cognome e nome o denominazione sociale FERRI AUTO SRL	
		codice fiscale 01644910364	comune di nascita	prov. nascita data nascita
		indirizzo		
		C.A.P.	luogo residenza	prov. residenza
NOMINATIVO	<input type="checkbox"/>		cognome e nome o denominazione sociale	
		codice fiscale	comune di nascita	prov. nascita data nascita
		indirizzo		
		C.A.P.	luogo residenza	prov. residenza

### C GRAVAMI IPOTECHE ANNOTAZIONI

ANNOTATA CESSAZIONE DELLA CIRCOLAZIONE PER ESPORTAZIONE IL 28/11/2000  
Certificazione sostitutiva del certificato di proprietà art.8 D.M.514/92  
Prima presentazione del 28/11/2000

importo riscosso per lire *****74.400 (EURO *****38,42)	di cui I.E.T. lire *****	di cui A.P.I.E.T. lire *****
--	-----------------------------	---------------------------------

NON UTILIZZABILE COME NOTA DI RICHIESTA	data 28/11/2000 IL FUNZIONARIO DEL P.R.A.
	MO A. BERGONZINI

### D IDENTITÀ artt. 5/6 legge 4 gennaio 1968 n. 15

A21176356

L'identità del soggetto indicato nel riquadro n.	è comprovata dalla esibizione del documento rilasciato da	in data
firma dell'interessato	data	firma del funzionario

Imposta di bollo assolta in modo virtuale - Autorizzazione dell'Intendenza di Finanza di Roma n. 68775 del 18/11/1975





UFFICIO PROVINCIALE DI:

2ª PRESENTAZIONE

1ª PRESENTAZIONE,

TARGA

nota di richiesta della seguente FORMALITÀ

CODICE

<b>M</b> A FAVORE	cognome o denominazione sociale		tipo società	
	nome		sesso	
	codice fiscale	comune di nascita		prov. data nascita
	indirizzo (via/piazza)		num. civico	
	C.A.P.	luogo residenza (comune)	luogo residenza (frazione)	prov. sogg. favore n.

Il veicolo di cui al presente certificato di proprietà n. di seguito indicato/i, per il quietanzato prezzo di lire acquirente/i

è stato verbalmente venduto allo/agli acquirente/i, con ogni garanzia di legge

Atto soggetto - non soggetto ad I.V.A.

data ..... firma del venditore .....

AUTENTICAZIONE DI FIRMA

REPERTORIO N. \_\_\_\_\_ lo dr. \_\_\_\_\_, notaio in \_\_\_\_\_

Iscritto al Collegio Notarile di \_\_\_\_\_  
certifico che la/le parte/i di seguito indicata/e, della cui identità personale sono certo, ha/hanno sottoscritto in mia presenza la dichiarazione di vendita che precede.  
parte/i \_\_\_\_\_

previa concorde rinuncia all'assistenza dei testimoni

BOLLO  
E  
SIGILLO

luogo e data \_\_\_\_\_

firma del notaio .....

<b>P</b> DOCUMENTAZIONE	<b>ATTO</b>		data _____ forma _____ prezzo/valore del veicolo (lire) _____		<b>S</b> SOMME	1ª PRESENTAZIONE		2ª PRESENTAZIONE			
	data registrazione _____ numero registrazione _____ luogo registrazione _____					IMPOSTA ERARIALE TRASCRIZ.					
	CESSAZ. CIRCOLAZ. CAUSALE CESSAZIONE	SI ALLEGA CARTA CIRCOL. <input type="checkbox"/>	SI ALLEGANO TARGHE <input type="checkbox"/>	FURTO O LIMITAZIONI		data: furto/rientro possesso/scadenza limitazione _____	SOVRATTASSA I.E.T.				
		causale cessazione _____				importo a concorrenza (lire) _____	ADDITIONALE PROVINCIALE I.E.T.				
	CARTA CIRC.	data aggiornamento _____	data nuovo rilascio _____	LEASING <input type="checkbox"/>		PATTO RISERV. DOMINIO <input type="checkbox"/>	SOVRATTASSA ADDIZIONALE PROV. I.E.T.				
	<b>BARRARE LE CASELLE CHE INTERESSANO</b>		ATTO SOGGETTO AD I.V.A. <input type="checkbox"/>	REGIME MATRIM. SEPARAZIONE BENI <input type="checkbox"/>		RICHIESTA URGENTE <input type="checkbox"/>	EMOLUMENTI E DIRITTI				
	altri dati _____					IMPOSTA DI BOLLO					
						TOTALE (cifre)					
						CONVALIDA UFFICIO					
						TOTALE (lettere)			PRIMA PRESENTAZIONE		
					TOTALE (lettere)			SECONDA PRESENTAZIONE			
<b>R</b> EDENTE					generalità _____						
					data esecuzione formalità _____	IL CONSERVATORE _____					

Stampa e Ologramma GRAFICHE GERCAP - Foggia-Roma

Imposta di bollo assolta in modo virtuale - Autorizzazione dell'Intendenza di Finanza di Roma n. 91295/73 del 28/11/73

DICHIAZIONE DI VENDITA Art. 19 RD n. 18/1/1977

NP-1B

# Ferri auto

FERRIAUTO s.r.l  
41100 Modena  
P.le Risorgimento, 1

Tel (059) 217561  
Fax (059) 225863  
P. IVA 0164491 0364

Mr.

SONOMA, CA 95476 (U.S.A.)

Modena, 31 agosto 2000

## FATTURA NO 72/AE

### DESCRIZIONE

VENDITA N. 1 AUTOVETTURA USATA, VISTA E ACCETTATA NELLO STATO  
IN CUI SI TROVA:

- MARCA TIPO:  
FERRARI F 129 AD (355 spider)
- TELAIO  
ZFFPR48B000102248

**TOTALE FATTURA**  
(IVA INCLUSA)

**L 137.000.000**

Operazione assoggettata al regime del  
margine globale ART 36.6 comma del  
D.L. N.41 del 23.02.95, convertito con  
modif. dalla Legge n,85 del 22.03.1995

Esente da Bollo ai sensi dell'Art.6,  
2 comma del DPR N 642 del 26.10.72e  
successive modificazioni



ENZO FERRI



# G & K AUTOMOTIVE CONVERSION, INC.

3231 S. STANDARD AVE. SANTA ANA, CA 92705-5641  
(714) 545-9503 FAX (714) 545-7667

(714) 545-7667

October 30, 2000

S  
Fax 011-39-59

US F

2 Pages Total

FAXED  
10/30/00

3:35/2am

Re: Ferrari

Dear !

We would like to thank you for your interest in our company for your automotive conversion needs. We have been in business for over twenty years and we are the largest modifier in the country, having modified thousands of vehicles. We are certified by California as well as government agencies, (DOT and EPA).

The cost to modify your vehicle is \$12,500.00. The estimated time is 8-10 weeks. G&K Automotive Conversion Inc. will allow a \$1,500.00 deduction for a new Cat and speedometer.

If you have any further questions, please do not hesitate to call, fax, or email me at [george@gnkauto.com](mailto:george@gnkauto.com). Thank you.

Sincerely,

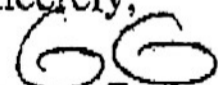
  
George Gemayel

Sosi

sent \$7500  
11/1/01

# G & K AUTOMOTIVE CONVERSION, INC.

3231 S. STANDARD AVE. SANTA ANA, CA 92705  
(714) 545-9503 FAX (714) 545-7657

## BONDING AND CLEARING REQUIREMENTS - DOCUMENTS/CHARGES

### DOCUMENTS REQUIRED:

- COPY OF BILL OF SALE \*
- COPY OF ORIGINAL FOREIGN TITLE \*
- CUSTOMS POWER OF ATTORNEY (SEE INSTRUCTION SHEET ATTACHED TO POWER OF ATTORNEY FORM)
- ORIGINAL BILL OF LADING FOR OCEAN SHIPMENT, AIRLINE AND AIRWAY BILL NUMBER FOR AIR SHIPMENT \*
- LIST OF ANY CONTENTS IN TRUNK. INVOICES REQUIRED FOR ITEMS CONSIDERED NEW (LESS THAN 8 MONTHS OLD)

\* NOTE \* NAME ON ABOVE DOCUMENTS SHOULD MATCH

### BONDING AND CLEARING CHARGES:

- CUSTOMS ENTRY AND CLEARING FEE ----- \$300.00
- CUSTOMS DUTY (SUBJECT TO LIQUIDATION) ----- 2.5% OF
- VALUE SHOWN ON BILL OF SALE PLUS CUSTOMS HANDLING FEES
- BONDING PREMIUM ----- 3% OF VALUE SHOWN ON BILL
- OF SALE (\$250.00 MINIMUM)
- BOND APPLICATION FEE ----- \$250.00
- BOND RELEASE FEE ----- \$153.15
- EPA PROCESSING FEE ----- 1% OF VALUE
- DOT/EPA WARRANTY FEES - (AS APPLICABLE) ----- \$350.00 EACH
- TRUCKING CHARGES FROM LONG BEACH TO G & K ----- \$ 85.00
- PORT HUENEME TO G & K ----- \$225.00

(Trucking company will charge extra for standby time if port agent does not deliver vehicle to driver in a timely fashion which will be passed on to customer)

- FREIGHT/DOCK HANDLING AND/OR ANY STORAGE CHARGES OWED.
- DOT PETITION FEES MAY APPLY TO CERTAIN MODELS.

PLEASE NOTE - CUSTOMS MAY REQUIRE YOUR VEHICLE TO BE PHYSICALLY EXAMINED. VEHICLES WHICH REQUIRE EXAM ARE SUBJECT TO ADDITIONAL COSTS INCURRED IN MOVING VEHICLE TO EXAM SITE AND BROKERS/WAREHOUSE FEES FOR HANDLING EXAM. ALSO - VEHICLES SHIPPED IN CONTAINERS INCUR ADDITIONAL CHARGES FOR MOVING AND DEVANNING CONTAINERIZED SHIPMENTS.

ALL DOCUMENTS SHOULD BE FORWARDED TO EITHER G & K OR CUSTOMHOUSE BROKER (SHOWN ON POWER OF ATTORNEY)

CHARGES FOR BONDING AND CLEARING ARE PAYABLE UPON PRESENTATION OF INVOICE. CHARGES FOR CONVERSION ARE PAYABLE UPON COMPLETION OF CONVERSION (PARTIAL DEPOSIT WILL BE REQUIRED). FINAL PAYMENT MUST BE IN THE FORM OF CASH OR CASHIER'S CHECK ONLY. ANY PAYMENTS IN THE FORM OF PERSONAL OR COMPANY CHECK ARE SUBJECT TO PAYMENT BY CUSTOMER'S BANK PRIOR TO RELEASE OF VEHICLE. ALL PRICES SUBJECT TO CHANGE WITHOUT NOTICE.

THANK YOU!





FERRIAUTO s.r.l.  
41100 Modena  
P.le Risorgimento, 1

Trib. di Modena  
Isc. 23760  
Cap. Soc. L.21.000.000

Tel (059) 217561  
Fax (059) 225863  
R. IVA 0164491 0364

Mr.

SONOMA, CA 95476 (U.S.A.)

Modena, 31 ottobre 2000

**FATTURA N° 72 / AE**

DESCRIZIONE

VENDITA N.1 AUTOVETTURA USATA, VISTA E ACCETTATA NELLO STATO  
IN CUI SI TROVA:

- \* MARCA TIPO:  
FERRARI F 129 AD ( 355 spider)
- \* TELAIO:  
ZFFPR48B000102248

**TOTALE FATTURA**

**L.137.000.000**

(IVA INCLUSA)

Operazione assoggettata al regime del  
margine globale ART.36, 6° comma del  
D.L. N.41 del 23.02.95, convertito con  
modif. dalla Legge n.85 del 22.03.1995

Esente da Bollo ai sensi dell'Art.6,  
2° comma del DPR N.642 del 26.10.72 e  
successive modificazioni

**FERRI AUTO S.R.L.**  
**P.LE RISORGIMENTO,1**  
**41100 MODENA ITALY**  
**PARTITA IVA 01644910364**

FAX 0039- 059-4393344  
TEL. 059-225863  
059-217561

Egr. Sig. Sl \_\_\_\_\_

\_\_\_\_\_  
Sonoma, CA 95476

Modena, 31 ottobre 2000

FATTURA PROFORMA N.1

Vendita vettura FERRARI F 129 AD (355 Spider)  
targata **AG800YG**  
telaio : ZFFPR48B000102248  
colore rosso

Importo di Lit. 137.000.000



TO: MR LUCIANO BEDINI

FROM: \_\_\_\_\_ ☺

8TH NOVEMBER, 2000

SONOMA, CA 95476 FA \_\_\_\_\_ ☺

DEAR MR BEDINI,

IT WAS A PLEASURE TO MEET YOU IN MODENA LAST WEEK.

HERE ARE THE DETAILS YOU REQUIRE:

PLEASE SEND:

1. COPY OF THE BILL OF SALE
2. COPY OF ORIGINAL FOREIGN TITLE
3. ORIGINAL BILL OF LADING

ALL THESE DOCUMENTS MUST BE SENT TO :

G & K AUTOMOTIVE CONVERSION, INC.  
3231 S. STANDARD AVE  
SANTA ANA, CA 92705  
USA

ATTENTION: GEORGE GEMAYEL  
FAX: (714) 545-7667

PLEASE SEND ME A FAX (707) 939-9235 ONCE YOU HAVE THE FERRARI AND CAN CONFIRM YOU HAVE ALL THE PAPERWORK. I WOULD ALSO LIKE TO KNOW THE EXPECTED DATE OF ARRIVAL AT LONG BEACH.

THANK YOU - YOURS SINCERELY

S. \_\_\_\_\_ ☺

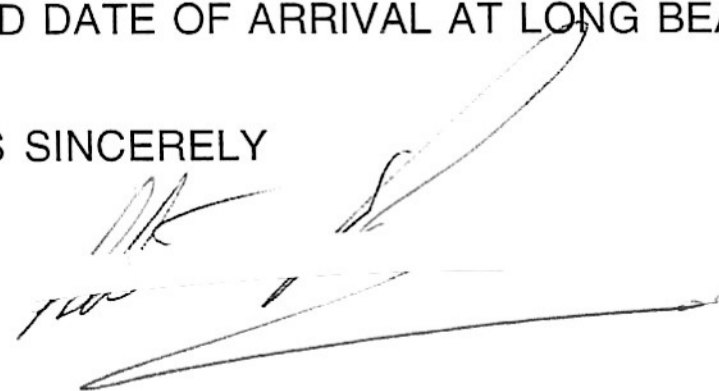
Handwritten signature and scribbles, including a large flourish and a horizontal line.









US Department  
of Transportation  
National Highway  
Traffic Safety  
Administration

# — DECLARATION —

## Importation of Motor Vehicles and Motor Vehicle Equipment Subject to Federal Motor Vehicle Safety, Bumper and Theft Prevention Standards

OMB No. 2127-0002  
Public Law 100-562,  
49 USC 301

PORT OF ENTRY LONG BEACH	CUSTOMS PORT CODE 2704	CUSTOMS ENTRY NO 692-0129945-3	ENTRY DATE 1-2-01
MAKE OF VEHICLE FERRARI	MODEL 355	YEAR 1995	VEHICLE IDENTIFICATION NUMBER (VIN) ZF F P R 4 8 B 0 0 0 1 0 2 2 4 8
REGISTERED IMPORTER NAME AND NHTSA REGISTRATION NUMBER (Required when Box 3 is checked) G & K AUTO COMV. R90007			VEHICLE ELIGIBILITY NO. (Box 3) VSP355
DESCRIPTION OF MERCHANDISE IF MOTOR VEHICLE EQUIPMENT			

1. The vehicle is 25 or more years old or the equipment item was manufactured on a date when no applicable Federal Motor Vehicle Safety, or Theft Prevention Standard was in effect. [591.5(i)]

2A. The vehicle, chassis-cab or equipment item conforms with all applicable Federal Motor Vehicle Safety Standards (or the vehicle does not conform solely because readily attachable equipment items which will be attached to it before it is offered for sale to the first purchaser for purposes other than resale are not attached), and Bumper and Theft Prevention Standards, and bears a certification label or tag to that effect permanently affixed by the original manufacturer to the vehicle or chassis-cab, or affixed by the manufacturer to the equipment item or its delivery container in accordance with applicable National Highway Traffic Safety Administration (NHTSA) regulations [591.5(b)]; or

**Attachment:** For chassis-cab entry, see Box 9.

2B. The vehicle conforms with all applicable Federal Motor Vehicle Safety Standards of Canada and the United States except for minor labeling requirements, and I am importing it for personal use.

**Attachment:** Copy of manufacturer's confirmation letter.

3. The vehicle does not conform with all applicable Federal Motor Vehicle Safety and Bumper Standards, but does conform with applicable Federal Theft Prevention Standards, but I am eligible to import it because NHTSA has determined that the model and model year of the vehicle to be imported is eligible for importation into the United States and I have furnished a bond, which is attached to this declaration, in an amount equal to 150 percent of the entered value of the vehicle as determined by the Secretary of the Treasury. If the Administrator of NHTSA determines that the vehicle has not been brought into compliance with all such standards within 120 days after importation, then I state that I will deliver such vehicle to the Secretary of the Treasury for export, or abandon it to the United States [591.8]; and that

a. I have registered with NHTSA pursuant to 49 CFR Part 592 and such registration has not been revoked or suspended; or

b. I have executed a contract or other agreement, which is attached to this declaration, with an importer who has registered with NHTSA and whose registration has not been suspended or revoked. [591.5(f)]

**Attachments:** Copy of DOT Bond; and  
Copy of Contract with a Registered Importer, if applicable.

4. The vehicle or equipment does not comply with all applicable Federal Motor Vehicle Safety, Bumper and Theft Prevention Standards, but is intended solely for export and is labeled for export on the vehicle or equipment item, and the outside of any

d. I will obtain from the Office of Foreign Missions of the State Department, before departing the United States at the conclusion of a tour of duty, an ownership title to the vehicle good for export only; and

e. I have attached a copy of my official orders. [591.5(h)(1)]

Name of Embassy: \_\_\_\_\_

**Attachment:** Copy of Official Orders.

7. The vehicle or equipment does not comply with all Federal Motor Vehicle Safety and Bumper Standards, but is being imported solely for the purpose of research, investigations, show or display, demonstrations or training, or competitive racing events, and I state that I will comply with the applicable restrictions on importers of such merchandise [591.7] and I will provide the Administrator with documentary proof of export or destructions not later than 30 days following the end of the period for which the vehicle has been admitted into the United States. [591.5(j)]

**Attachment:**

a. Copy of NHTSA permission letter if the importer is not an original manufacturer of motor vehicles (or a wholly owned subsidiary thereof) that are certified to comply with all applicable Federal Motor Vehicle Safety Standards (FMVSS). Use on the public roads must be authorized specifically. [591.6(f)(1) or (2)];

b. Importer's statement describing the use to be made of the vehicle or equipment item if the importer is an original manufacturer of motor vehicles (or a wholly owned subsidiary thereof) that are certified to comply with all applicable FMVSS. If use on the public roads is an integral part of the purpose for which the vehicle or equipment item is imported, the statement shall describe the purpose which makes such use necessary, state the estimated period of time during which use of the vehicle or equipment item on the public roads is necessary, and state the intended means of final disposition (and disposition date) of the vehicle or equipment item after completion of the purpose for which it is imported. [591.6(f)(3)]

8. This vehicle was not manufactured primarily for use on the public roads and thus is not a motor vehicle subject to the Federal Motor Vehicle Safety, Bumper and Theft Prevention Standards or the equipment item is not a system, part, or component of a motor vehicle and thus is not an item of motor vehicle equipment subject to the Federal Motor Vehicle Safety Standards. [591.5(a)]

**Attachment:** Importer's substantiating statement. [591.6(a)]

9. The vehicle or equipment item requires further manufacturing operations to perform its intended function, other than the addition of readily attachable equipment items such as mirrors, wipers, or tire and rim assemblies, or minor finishing operations



ENTRY SUMMARY

110 11  
5567739

BOX # PMS 692

NIK & ASSOCIATES  
800 SO HINDRY AVENUE UNIT A  
INGLEWOOD, CA 90301  
1-310-215-8282 (ESMERALD)

1. Entry No. 0139945-3	2. Entry Type Code 01 ABI/A	3. Entry Summary Date 01/16/01
4. Entry Date 01/03/01	5. Port Code 2704	
6. Bond No. 276	7. Bond Type Code B	8. Broker / Importer File No. CHB 0139945

9. Ultimate Consignee Name and Address  81 800 SONOMA, CA 95476	10. Consignee No. 2-4414	11. Importer of Record Name and Address B & K AUTO CO 3231 S STANDARD AVE SANTA ANA, CA 92705	12. Importer No. 95-3761804
---	-----------------------------	--	--------------------------------

13. Exporting Country YY	14. Export Date 12/03/00
15. Country of Origin IT	16. Missing Documents NONE
17. I.T. No.	18. I.T. Date

19. B L or AWB No. CCXLSTBDA00854F	20. Mode of Transportation 11	21. Manufacturer I.D. ITFERSFA1143MOD	22. Reference No. 95-6556673
---------------------------------------	----------------------------------	--	---------------------------------

23. Importing Carrier CCXL-CIELO D' ITALIA-014	24. Foreign Port of Lading 47537	25. Location of Goods/G.O. No. W158 CAL UNITED TERMINALS (LB
---	-------------------------------------	--

26. U.S. Port of Unlading 2704	27. Import Date 12/25/00
-----------------------------------	-----------------------------

28. Line No.	29. Description of Merchandise			33. A. Entered Value B. CHGS C. Relationship	34. A. T.S.U.S.A. Rate B. ADA/CVD Rate C. I.R.C. Rate D. Visa No.	35. Duty and I.R. Tax	
	30. A. T.S.U.S.A. No. B. ADA CVD Case No.	31. A. Gross Weight B. Manifest Qty.	32. Net Quantity in T.S.U.S.A. Units			Dollars	Cents
		1 CTNS		N			
001	PASSG VEHIC:USED;>15000 8703.23.0090	INV# 001, 1 CTNS 1510	1 NO	62061 C1510	2.5% .21% .125%	1551.50 130.33 77.56	
	G.I.V. US\$ N.E.V.	62061.00 62061.00					
BLOCK 39 SUMMARY:							
	MERCHANDISE PROCESSING FEE		499	130.33			
	HARBOR MAINTENANCE FEE		501	77.58			
	TOTAL:			207.91			
	TOTAL ENTERED VALUE			62061.00			

<p>36. Declaration of Importer of Record (Owner or Purchaser) or Authorized Agent</p> <p>I declare that I am the <input type="checkbox"/> importer of record and that the actual owner, purchaser, or consignee for customs purposes is as shown above. OR <input checked="" type="checkbox"/> owner or purchaser or agent thereof.</p> <p>I further declare that the merchandise was obtained pursuant to a purchase or agreement to purchase and that the prices set forth in the invoice are true. OR <input type="checkbox"/> was not obtained pursuant to a purchase or agreement to purchase and the statements in the invoice as to value or price are true to the best of my knowledge and belief.</p> <p>I also declare that the statements in the documents herein filed fully disclose to the best of my knowledge and belief the true prices, values, quantities, rebates, drawbacks, fees, commissions, and royalties and are true and correct, and that all goods or services provided to the seller of the merchandise either free or at reduced cost are fully disclosed. I will immediately furnish to the appropriate customs officer any information showing a different state of facts.</p> <p>Notice required by Paperwork Reduction Act of 1980. This information is needed to ensure that importers/exporters are complying with U.S. Customs laws, to allow us to compute and collect the right amount of money, to enforce other agency requirements, and to collect accurate statistical information on imports. Your response is mandatory.</p>	U.S. CUSTOMS USE		TOTALS		
	A. Liq. Code	B. Ascertained Duty	37. Duty	1551.50	
		C. Ascertained Tax	38. Tax	.00	
		D. Ascertained Other	39. Other	207.91	
		E. Ascertained Total	40. Total	1759.41	
41. Signature of Declarant, Title, and Date ATTY-IN-FACT		01/04/2001			

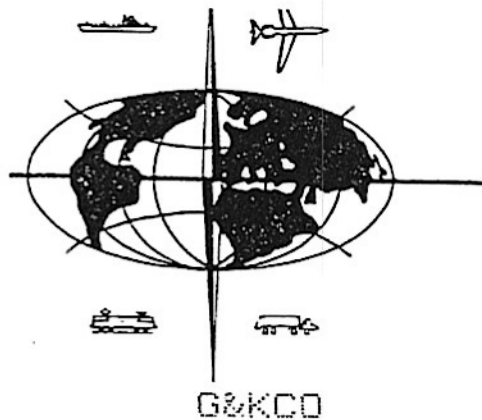

**NIK**  
**and associates**  
 customs broker  
 freight forwarder

P.O. Box 90279  
 Los Angeles, CA 90009-0279  
 Phone: (310) 215-8282  
 Fax: (310) 649-0324  
 e-mail: NIK@LAcustoms.com

7169 / 5587

**INVOICE**

OUR REF. NO.	YOUR REF. NO.
0139945	

INVOICE DATE	INVOICE NO.
01/10/2001	CHB 154954
DATE ARRIVED	B/L NO./AWB NO.
12/25/2000	SIGDA00854F
PORT OF LADING	VESSEL/AIRLINE
LEGHORN;	LIVCCXL/014ALY

**TO**  
 G & K AUTO CO  
 3231 S STANDARD AVE  
 SANTA ANA, CA 92705

MARKS AND NUMBERS	DESCRIPTION OF PACKAGES AND GOODS	ACCOUNT NO.
HB# E/C ESMEALD CNT# CPSU1607835	1 CTNS, 1995 FERRARI, 1510 KG ENTRY# 0139945-3 IR: G & K AUTO CO UC: S VESSEL NAME: CIELLO D' ITALIA	

	DESCRIPTION OF CHARGES	AMOUNT	
<p><b>IMPORTANT</b></p> <p>1. In the absence of specific terms of payment this invoice is due and payable upon presentation. The greater of a minimum service charge, or a maximum percentage allowed by law, will be added to the unpaid balance beyond due date and every month thereafter.</p> <p>2. This invoice covers cash advances and services including in each item of disbursement (except duty and freight) our profit or compensation for our services.</p> <p>3. If you are the importer of record, payment to the broker will not relieve you of liability for Customs charges (duties, taxes, or other debts owed Customs) in the event the charges are not paid by the broker. Therefore, if you pay by check, Customs charges may be paid with a separate check payable to the "U.S. Customs Service", which shall be delivered to Customs by the broker.</p> <p>4. Do not dispose of any part of a shipment until you have received ALL packages held for Customs examination. If you are unable to redeliver to Customs on demand, severe penalties may result.</p> <p>"See reverse side of this invoice for notice relating to our Terms and Conditions of Service."</p>	CUSTOMS EST DUTY/MPF/HMF SUBJECT TO LIQ.  ENTRY FEE  DEMURRAGE  MESSENGER SERVICE  SPECIAL HANDLING, SERVICES: AUTOS  DEVANNING  REF: SILVANO PAYNE / 1995 FERRARI *EA                      THANK YOU	1,759.44  300.00  169.00  40.00  50.00  350.00	
	<i>Thank you for using our Services</i> <b>PAYABLE UPON PRESENTATION</b>		<b>TOTAL DUE</b> 2,668.44

# Metropolitan Towing, Inc.

100 S. Hathaway St., Suite A • Santa Ana, CA 92701

(714) 835-3002

7169

08096

Date JAN-11-01 Driver #5

Customer G+K

Address 3231 S. STANFORD

City/State/Zip SANTA ANA

VIN #: ZFFR248B000102248

Color	Year	Make	Model	License #
RED	00	FERRARI	MONDO	N/A

Location CFR

1700 LINDSEY PKWY, FOND DU LAC

Destination G+K

SANTA ANA

Other Service/Information \_\_\_\_\_

\_\_\_\_\_

\_\_\_\_\_

\_\_\_\_\_

\_\_\_\_\_

\_\_\_\_\_

Total Miles 36

INVOICE TOTAL

### CHARGES

1st Hook	<u>85<sup>00</sup></u>	
2nd Hook		
Svc Call		
Mileage		
Time Chg		
Labor Chg		
Paid Out		
	<u>85<sup>00</sup></u>	

Charge to Customer's Account RO# \_\_\_\_\_ PO# \_\_\_\_\_

Paid in Full:  Cash  Check # \_\_\_\_\_  Credit Card \_\_\_\_\_

It is understood that the owner or his agent has examined said vehicle and agrees to release Metropolitan Towing, Inc. from any or all claims which may arise from damage to said vehicle or loss of public or private property.

I, THE UNDERSIGNED, DO HEREBY CERTIFY THAT I AM LEGALLY AUTHORIZED AND ENTITLED TO TAKE POSSESSION OF THE VEHICLE DESCRIBED ABOVE AND ALL PERSONAL PROPERTY THEREIN.

SIGNATURE [Signature]

Address \_\_\_\_\_

City/State/Zip \_\_\_\_\_



G & K AUTOMOTIVE CONVERSION, INC.  
3231 S. STANDARD AVE.  
SANTA ANA, CA 92705

# INVOICE

5587

PHONE (714) 545-9503  
FAX (714) 545-7057

DATE  
**3/16/01**

CUSTOMER ORDER NO.  
**7169**

SALESPERSON  
**GG**

VIA  
**NIK # 0139945**

TO  
  
SONOMA, CA 95478

TERMS:

QUANTITY	DESCRIPTION	PRICE	AMOUNT
	CUSTOMS ENTRY FEE	\$300.00	\$300.00
	CUSTOMS DUTY (SUBJECT TO LIQUIDATION)	\$1,759.44	\$1,759.44
	BONDING PREMIUM	\$1,861.83	\$1,861.83
	BOND APPLICATION FEE	\$250.00	\$250.00
	BOND RELEASE FEE	\$153.15	\$153.15
	EPA PROCESSING FEE	\$620.61	\$620.61
	EPA/DOT WARRANTY	\$350.00	\$700.00
	MESSENGER SERVICE	\$40.00	\$40.00
	SPECIAL HANDLING SERVICES	\$50.00	\$50.00
	DEMURRAGE	\$169.00	\$169.00
	TOWING FROM PORT TO G & K	\$85.00	\$85.00
	DEVANNING	\$350.00	\$350.00
	CARB CERTIFICATE	\$350.00	\$350.00
	<b>TOTAL</b>		<b>\$6,689.03</b>

THANK YOU

 To Reorder:  
800-225-6360 or naps.com

Translation of letter from my Uncle in Milan, Italy

Dear ( \_\_\_\_\_ )

I hope you are keeping well and also your family.

As you requested in your telephone call, here is the letter to confirm that you stayed with me and your cousin Fiorella from the period end of August to the end of November 2000.

You left only to go to The Netherlands and Greece but the rest of the time you were here using your Ferrari in Milano.

I do hope that this letter of mine will help you, many dear regards to Kathy and the kids and a big hug to you

Uncle Ferruccio

Via Regina S  
Milano, Italy.

20 Aprile 2001

Carissimo -<sup>o</sup>

Spero che stai bene, così pure come la tua bella famiglia.

Come per la tua richiesta al telefono, eccoti qui la mia lettera che conferma il tuo soggiorno a Milano, con me e con tua cugina Fiorella, entro il periodo fine Agosto fine Novembre 2000.

Si sei assentato solo di qualche giorno per andare in Olanda e Grecia, ma per il resto del tempo hai usato la tua Ferrari estensivamente qui a Milano.

Con la speranza che questa mia lettera ti sia d'aiuto, tanti cari saluti a Kathy e bambini, a te un grosso abbraccio

L. S.



EPA

United States Environmental Protection Agency
Washington, DC 20460
Application for Final Admission
Nonconforming Imported Vehicle

Form Approved
OMB No. 2060-0095
Approval expires 3-31-94

Warning: Any person who knowingly makes any false or fraudulent statement or conceals a material fact shall be fined not more than \$250,000 or Imprisoned not more than 5 years or both. 18 United States Code 1001

Port of Entry 2704, 2. Entry Date(moldd/yr) 1/3/01, 3. Entry Number 692-0139945-3, 4. Vehicle ID No. (VIN) or Heavy-Duty Engine No. ZFFPR48B000102248, Date of Original Manufacture (mo/yr) May-95, 6. Original Manufacturer FERRARI, 7. Model F355, Declaration Code (See box 8 on EPA form 3520-1) C, 9. EPA No. and Model Year and Expiration Date of Certificate Applicable to This Importation G & K AUTO CONV. 251LDV01 12/31/01

Names, Addresses, and Telephone Numbers of Relevant Parties

11. Owner (if not ICI) S... SONOMA, CA 95476, 12. Intended Storage Location (No PO Boxes) G&K Auto Conversion 3231 S. Standard Ave Santa Ana, Ca 92705, Telephone Number (714) 545-9503, Taxpayer ID# (SSN) 472-92-4414, Telephone Number (714) 545-9503, 15. Modification Date 2/6/01, Person to Receive Oral or written Notification that EPA is not Approved Vehicle for Final Admission George Gemayel

First Test Results (Mark 'X' in one box only) [ ] Cert. Car (write sequence number in box beginning with the first car imported under the certificate which is the cert. prototype) [X] Modification/Test

Name of Test Laboratory CALIFORNIA ENVIRONMENTAL ENGINEERING

Test results adjusted by the deterioration factor and rounded to two significant figures using ASTM E 29-67 rounding procedures :

Table with columns: Date of Test, g/mi, HC, CO, NOX, Evap. (Gas only), Part. (Diesel only), Deterioration Factor, and adjusted results in g/mi and g/test.

Table for Second Test Results (if applicable) with columns: Date of Test, g/mi, HC, CO, NOX, Evap.(Gas only), Part(Diesel only), Deterioration Factor, and adjusted results in g/mi and g/test.

Combined Fuel Economy (ICIs report the combined fuel economy value from the last test for a modification and test vehicle. This does not include certified vehicles. A designated importer of a new Canadian vehicle shall report the combined fuel economy value of the vehicle as determined during the OEM's EPA certification process.)

mi/gal (Round fuel economy to the nearest tenth using ASTM E 29-67)

14.7

19. For EPA Use Only

Date final admission form received

20. Place an "X" in only one box

- I certify that the vehicle or heavy-duty engine has been modified in accordance with the provisions of a currently valid certificate of conformity. EPA has approved the plan for me to receive information concerning OEM running changes that affect emissions and therefore testing was not required. (40 CFR 85.1505(a)(2)(i))
- I certify that the vehicle or heavy-duty engine has been modified in accordance with the provisions of a currently valid certificate of conformity. If applicable, a Federal Test Procedure was performed on the vehicle or heavy-duty engine in accordance with procedures in 40 CFR Part 86 at a laboratory in the U.S. (40 CFR 85.1505(a)(2)(i))
- I certify that the vehicle or heavy-duty engine has been modified and the Federal Test Procedure was performed on the vehicle or heavy-duty engine in accordance with procedures in 40 CFR Part 86 at a laboratory in the U.S. The emission testing and development of fuel economy data were performed after modification to Department of Transportation safety standards. (40 CFR 85.1509(g)(2))
- I certify that the vehicle or heavy-duty engine has been modified and the Federal Test Procedure was performed in accordance with procedures in 40 CFR Part 86 at a laboratory in the U.S. because it qualifies for the transition period option in 40 CFR 85.1509(b)-(f). The vehicle is the same make and fuel type as the vehicle for which I have received an EPA certificate of conformity. The emission testing and development of fuel economy data were performed after modification to Department of Transportation safety standards.
- I certify that the vehicle or heavy-duty engine is a new Canadian vehicle on EPA's pre-approved list.

21. I certify that as the certificate holder or designated importer of new Canadian vehicles I have provided or will provide the following to the purchaser or owner of the vehicle or heavy-duty engine: (1) written instructions for maintenance and use as required by 40 CFR 85.1510(a) (not for designated importers of new Canadian vehicles), (2) an emissions warranty as described in 40 CFR 85.1510 (b), sections 207(a) and (b) of the Clean Air Act and 40 CFR Part 85, Subpart V, (3) an emission label as required by 40 CFR 85.1510(c) and 40 CFR Part 600, Subpart D, (4) a fuel economy label as required by 40 CFR 85.1510, (d) and 40 CFR Part 600, Subpart D. I certify that as the certificate holder or designated importer of new Canadian vehicles I have complied with the applicable provisions of the Energy Act of 1978, 26 USC 4064 (gas guzzler tax) and for vehicles not owned by me, I have provided the applicable tax forms to the owner; I have complied with the Corporate Average Fuel Economy requirements of the Energy Policy and Conservation Act, 15 USC 2001 et seq. and 40 CFR Part 600; I have complied with the requirements of 40 CFR 80.24 to affix applicable unleaded fuel labels; I am responsible for the vehicle or heavy-duty engine compliance with Federal emission requirements regardless of whether I own the vehicle or heavy-duty engine, I certify that I have read and understand the warning above regarding the submission of false or fraudulent statements or concealing a material fact, and the prohibited acts in 40 CFR 85.1513 and that the information I have provided is correct. I understand that EPA Enforcement Officers are authorized to conduct inspections or testing otherwise permitted by 40 CFR Part 85 or other applicable provisions of the law. I will hold this vehicle for at least 15 working days (3 working days for designated importers of new Canadian vehicles) from the date of EPA's receipt of this final admission information unless otherwise notified by EPA.

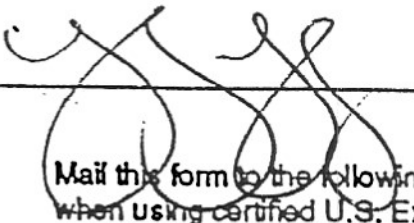
Signature of ICI Corporate Officer 	Print or type name George Gemayel	Date Signed 2/22/01
---	--------------------------------------	------------------------

<p>Mail this form to the following address when using certified U.S. Express Mail, or regular mail:</p> <p><b>Attn. FINAL ADMISSION</b> U.S. Environmental Protection Agency Manufacturers Operations Division (6405J) 401 M. St., S.W. Washington, DC 20460 (202) 233-9660</p>	<p><b>Mailing Instructions</b></p> <p>For delivery by a courier service (e. g., Federal Express, DHL, etc....) Only use the following address:</p> <p><b>Attn. FINAL ADMISSION</b> U.S. Environmental Protection Agency Manufacturers Operations Division (6405J) 501 3rd St., N.W. Washington, DC 20001 (202) 233-9660</p>	<p>For mail other than certified (Courier Service, U.S. Express or regular mail) include a self-addressed and stamped post card for EPA to stamp with our receipt date. For more information please call EPA at (202) 382-2504.</p> <p><b>Instructions to Designated Importers of New Canadian Vehicles:</b> In item 5 fill in the model year. Do not complete items 9,10,16, and 17</p>
---	---	--

**Privacy Act Statement**

Collection of the information on this form is authorized by the Clean Air Act, 42 USC sec. 7401 et. seq. (see 40 CFR sec. 85.1501 et seq., Importation of Motor Vehicles and Motor Vehicle Engines). The Environmental Protection Agency (EPA) uses this information to determine compliance of imported motor vehicles and heavy-duty engines with U.S. emission requirements and for investigations with respect to EPA's import regulations. Disclosure of this information may be made to other Federal, State or local law enforcement agencies when there is a violation of civil or criminal law. Furnishing the information on this form, is voluntary, but failure to do so may result in disapproval for entry into the U.S. of the motor vehicle or heavy-duty engine identified on this form.

**Paperwork Reduction Act Notice**

The public reporting burden for this collection of information is estimated to average 30 minutes per response. This estimate includes time for reviewing instructions, searching existing data sources, gathering and maintaining the needed data, and completing and reviewing the collection of information. Send comments regarding the burden estimate or any other aspect of this collection of information to the Chief, Information Policy Branch (PM-223), U. S. Environmental Protection Agency, 401 M Street, SW, Washington, DC 20460, and the Office of Information and Regulatory Affairs, Office of Management and Budget, Washington, DC 20503, marked Attention: Desk Officer for EPA.

**Subject:** ferrari 355

**Date:** Fri, 9 Feb 2001 18:45:09 +0100

**From:** "Giulia F." <zyme@libero.it>

**To:**

Egr Sig. I

Le invio, scusandomi per il ritardo, il conto dettagliato delle spese sostenute.

Lo specchio, il catalizzatore, la valvola, sono stati sostituiti con ricambi nuovi, per consegnarle l'auto nella condizione migliore.

Con solamente la riparazione si sarebbe ottenuto di certo un cattivo risultato.

Sono stati eseguiti dei lavori di meccanica non preventivati per rendere l'autovettura perfettamente funzionante. ←

**PREZZO ORIGINALE:**

£. 146.000.000

Disco frizione:

*Disk Brake, Clutch Disc, Pilot* E

£. 420.000

n. 2 Catalizzatori (£. 1500.000 x 2):

*2 catalytic converters* E

£. 3.000.000

Valvola marmitta (BAYPASS):

*valve for silencer* E

£. 1.920.000

n.1 specchio completo (£.1.300.000)

£.-----non conteggiato

n.1 interruttore specchi:

*switch mirror* ← ENZO

£. 119.000

Nuovo contamiglia

*mileometer*

£. 640.000

Manodopera:

*labour*

£. 600.000

Telo copriauto:

£. 300.000 ✓

Spese Banca:

£. 180.000 ✓

Radiazione e documenti:

£. 200.000 ✓

*119  
1.920  
3000  
420  
-----  
5459*

*640  
600  
300  
180  
200  
-----  
1920,000  
146  
-----  
147,920,000  
5,459  
-----  
153,419*

*Noe*



February 09, 2001

Caro Enzo e Giulia,

Grazi per la email. e per le spiegazioni che, purtroppo, non alleviano i miei dubbi sull'eccessivo costo che state imponendomi.

Parecchie delle riparazioni citate non erano mai state menzionate durante il nostro rapporto in Italia:

No.1 - Lo specchio: LIT.1.300.000 avrebbe dovuto comprendere l'interruttore, per il quale adesso domandate LIT.119.000;

No.2 - Catalizzatori: il nostro meccanico in Los Angeles mi ha assicurato che i presenti catalizzatori non sono nuovi, quindi sono obbligato a domandarvi come questo errore è stato possibile, visto che mi avete addebitato di ben LIT.3.000.000. Se tu mi assicuri che i catalizzatori sono veramente nuovi, per cortesia mandami un fax della fattura così che io posso mostrare questa al mio meccanico in Los Angeles.

No. 3 - Valvola Marmitta LIT.1.920.000, Enzo avevi promesso di cambiarla senza costo per me. Per quale ragione adesso il costo mi viene addebitato?

Sono veramente sconcertato che tu non rispondi alle mie domande che due o tre mesi dopo. Per piacere vediamo di rimanere amici e rispondi a queste questioni che sono importanti per me.

Saluti

# Automobile Consumer Service Corporation

## Warranty

Policy Number: 414261

Policy Effective Date: 2/26/01

Vehicle Make and Model: Ferrari ~~FX~~ f355

Vehicle Year: 1995

VIN: ZFFPR48B000102248

### Provided To: Policy Holder (Vehicle Owner)

Name: ~~XXXXXXXXXXXX~~ e

Address: \_\_\_\_\_

City, State, Zip: Sonoma, Ca 95476

Telephone Number: ( ) - - - - -

### Provided By Registered Importer

Name of RI: G & K Auto Conversion

Address: 3231 S. Standard Ave

City, State, Zip: Santa Ana, Ca 92705

RI Account Number: 003

---

The registered importer (hereinafter called "RI") warrants to the vehicle owner and any subsequent owner during the term at the time that the above referenced vehicle has been equipped so as to conform on the policy effective date with all applicable federal Motor Vehicle Safety and Bumper Standards prescribed under 49 CFR Part 571 and 581.

For the term of ten (10) years from the effective date, the "RI" will repair or replace, at no charge to the warranty holder, any of the parts as may be necessary to bring the owner's vehicle as identified herein into compliance with the applicable standards of remedy any safety related defect if such non-compliance or safety related defect is determined to exist in the above referenced vehicle under the regulations of the U.S. Department of Transportation but only to the extent and limited to the obligations imposed upon the "RI" by such regulations.

### IMPORTANT

The "RI's" obligation to remedy or replace any warranted parts as may be required hereunder is the sole and exclusive remedy available to the warranty holder and such obligation is in lieu of all other express policies; any implied warranty of merchantability or warranty of fitness for a particular use or purpose. In addition, the "RI" shall not be liable or responsible for any incidental, consequential, commercial or exemplary loss or damage resulting from (1) a breach of this policy, (2) any implied warranty, or (3) failure of any part of the vehicle.

### LIMITS OF LIABILITY

The total amount paid under this warranty shall not exceed \$2000.00 (two thousand dollars) in the aggregate for the remedy of each non-compliance or safety related defect that may be determined to exist in the vehicle .

# G & K AUTOMOTIVE CONVERSION, INC.

3231 S. STANDARD AVE. SANTA ANA, CA 92705  
(714) 545-9503 FAX (714) 545-7667

## OWNER'S MANUAL INFORMATION EMISSION CONTROL INFORMATION

This vehicle: Year 1995 Make FERRARI Model F355  
VIN ZFFPR48B000102248 is equipped with the retrofit parts  
checked below:

	<u>Vendor</u>	<u>Part No.</u>
( X ) CATALYTIC CONVERTER	<u>FERRARI</u>	<u>163198</u>
( X ) OXYGEN SENSOR (O <sub>2</sub> )	<u>FERRARI</u>	<u>155010</u>
( X ) COMPUTER CONTROL (Lambda)	<u>FERRARI</u>	<u>155006</u>
( ) EXHAUST GAS RECIRCULATION VALVE	<u>N/A</u>	<u>N/A</u>
( X ) AIR PUMP	<u>FERRARI</u>	<u>148049</u>
( X ) PULSE AIR VALVE	<u>FERRARI</u>	<u>170442</u>
( X ) DIVERTER VALVE	<u>FERRARI</u>	<u>147390</u>
( X ) CHARCOAL CANISTER	<u>FERRARI</u>	<u>16045</u>
( X ) CHECK VALVE	<u>FERRARI</u>	<u>148494</u>
( ) WARM UP REGULATOR (OEM) MODIFIED	<u>N/A</u>	<u>N/A</u>
( ) PRE-CATALYTIC CONVERTER	<u>N/A</u>	<u>N/A</u>
( ) FREQUENCY VALVE	<u>N/A</u>	<u>N/A</u>

The catalytic converter (CAT) is an emission reducing device, designed to reduce exhaust gases (HC, CO, NOX) prior to the exhaust being emitted into the atmosphere. See schematic page 3.

The oxygen sensor (O<sub>2</sub>S) operates in conjunction with the computer control (Lambda) and Frequency valve if so equipped. The O<sub>2</sub> sensor senses oxygen in the exhaust ahead of the CAT. The O<sub>2</sub> sensor then sends a signal to the computer control (Lambda) which in turn opens and closes the frequency valve at a very high rate to constantly adjust the air/fuel ratio. See schematic page 3, 4, and 6.

The A.I.R. system (Air pump, Diverter valve or Pulse air) if so equipped, pumps ambient air into the exhaust system to aid the CAT in the oxidation process. See schematic page 4.

The exhaust gas recirculation valve, (EGR) if so equipped, recirculates a portion of exhaust gas back into the intake system to dilute the intake mixture, which in turn reduces the combustion chamber temperature in an effort to control oxides of nitrogen. The EGR valve is a vacuum operated device. See schematic page 4.



OWNER'S MANUAL INFORMATION  
EMISSION CONTROL INFORMATION  
(Continued)

The charcoal canister system consists of a charcoal canister, check valve and fuel line hose. The fuel line hose is attached to the gas tank vent line then runs to the check valve, from the check valve the line runs to the tank port on the charcoal canister. A vacuum line also runs from the vacuum port on the canister to a ported vacuum source to purge the canister. The check valve allows vapor to the canister but closes should any gasoline get in the vent system.

For periodic maintenance see maintenance schedule. All retrofit parts are available from Rhinetrade, Inc., phone number (714) 444-9120 or the original manufacturer listed on the parts list.

Should your mechanic have any technical questions regarding system diagnostic problems please refer him to AMG USA, INC., phone number (714) 545-7777. System function check should be done according to procedures outlined in any Mitchell Manual or manufacturer service manual.

### BASIC CATALYTIC CONVERTER LAYOUT

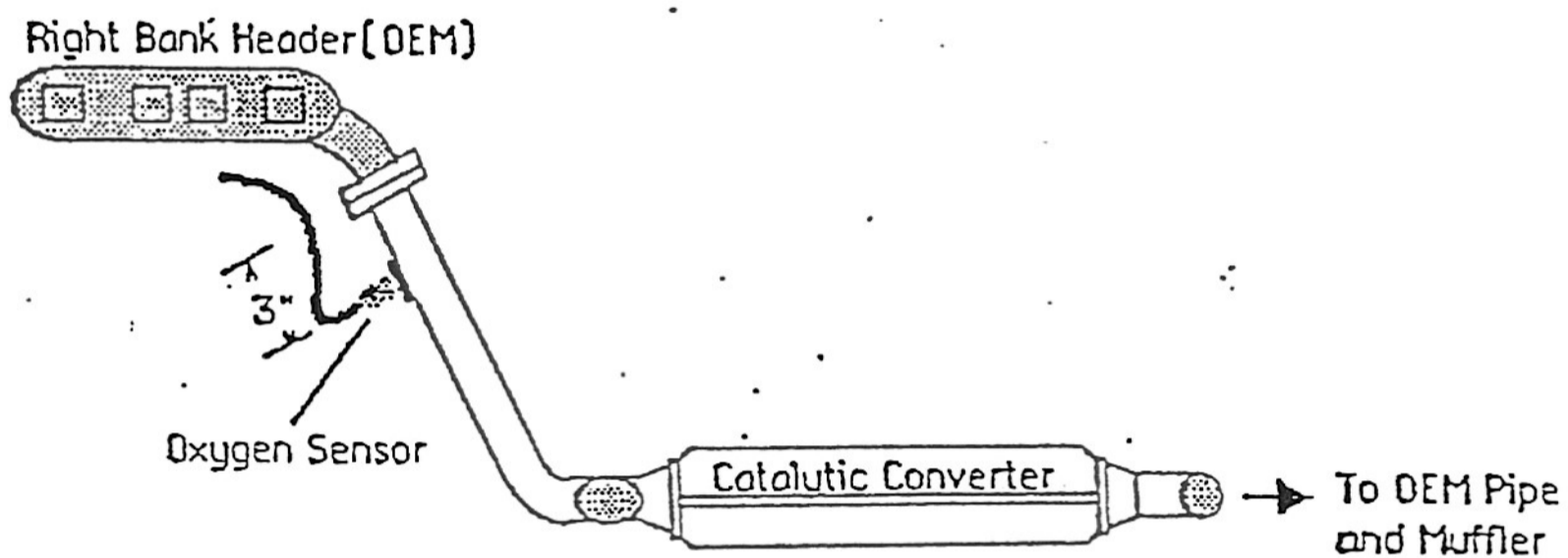

Side view of Catalytic Converter Layout [Not to scale]  
[Left side down pipe omitted for clarity]

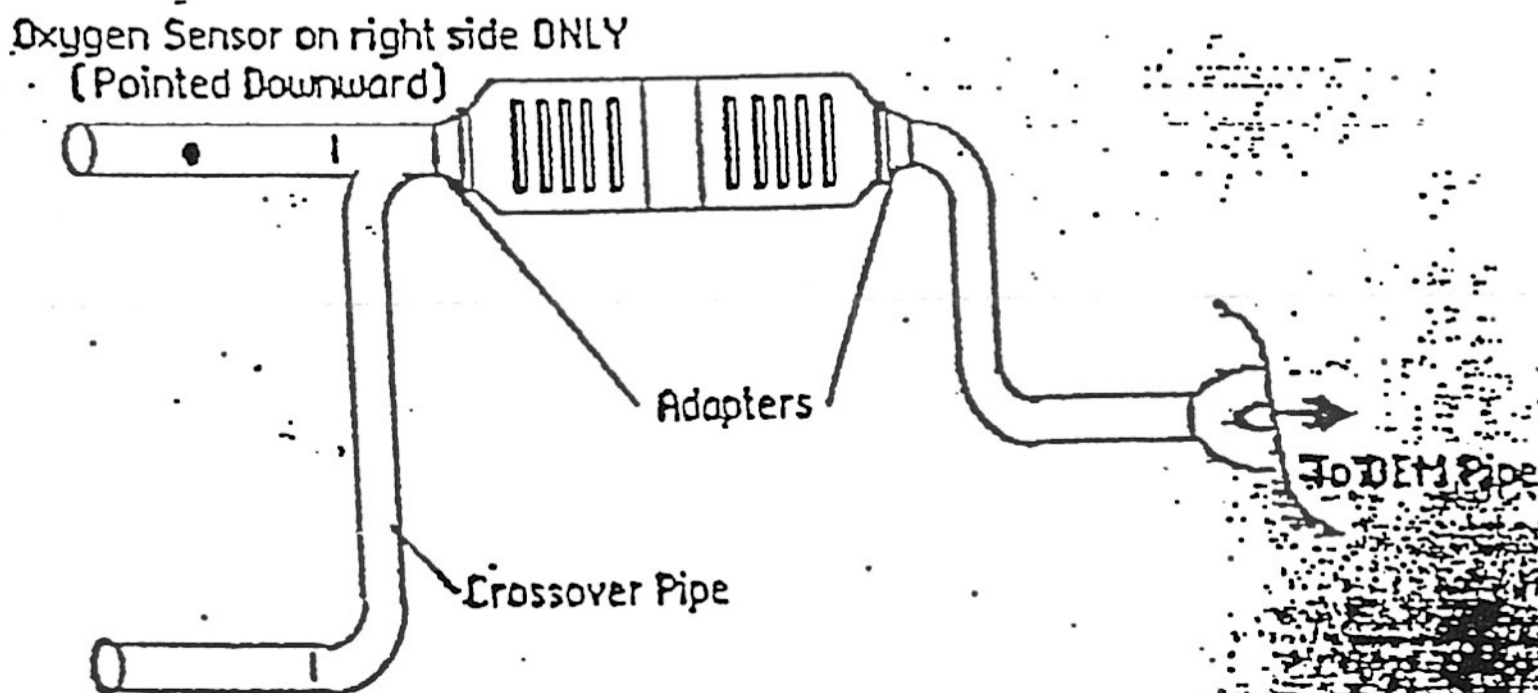

Top View of the Catalytic Converter Layout

FUEL SYSTEM DIAGRAM

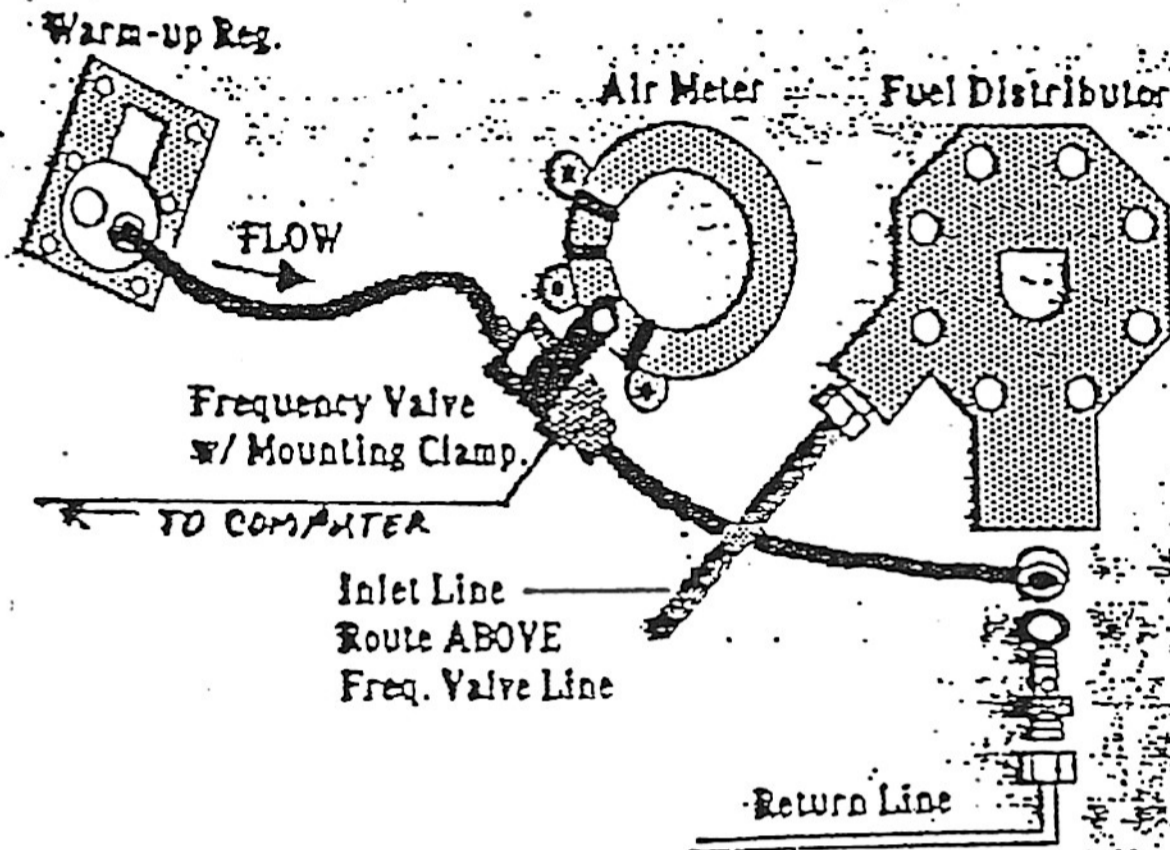

VACUUM DIAGRAM

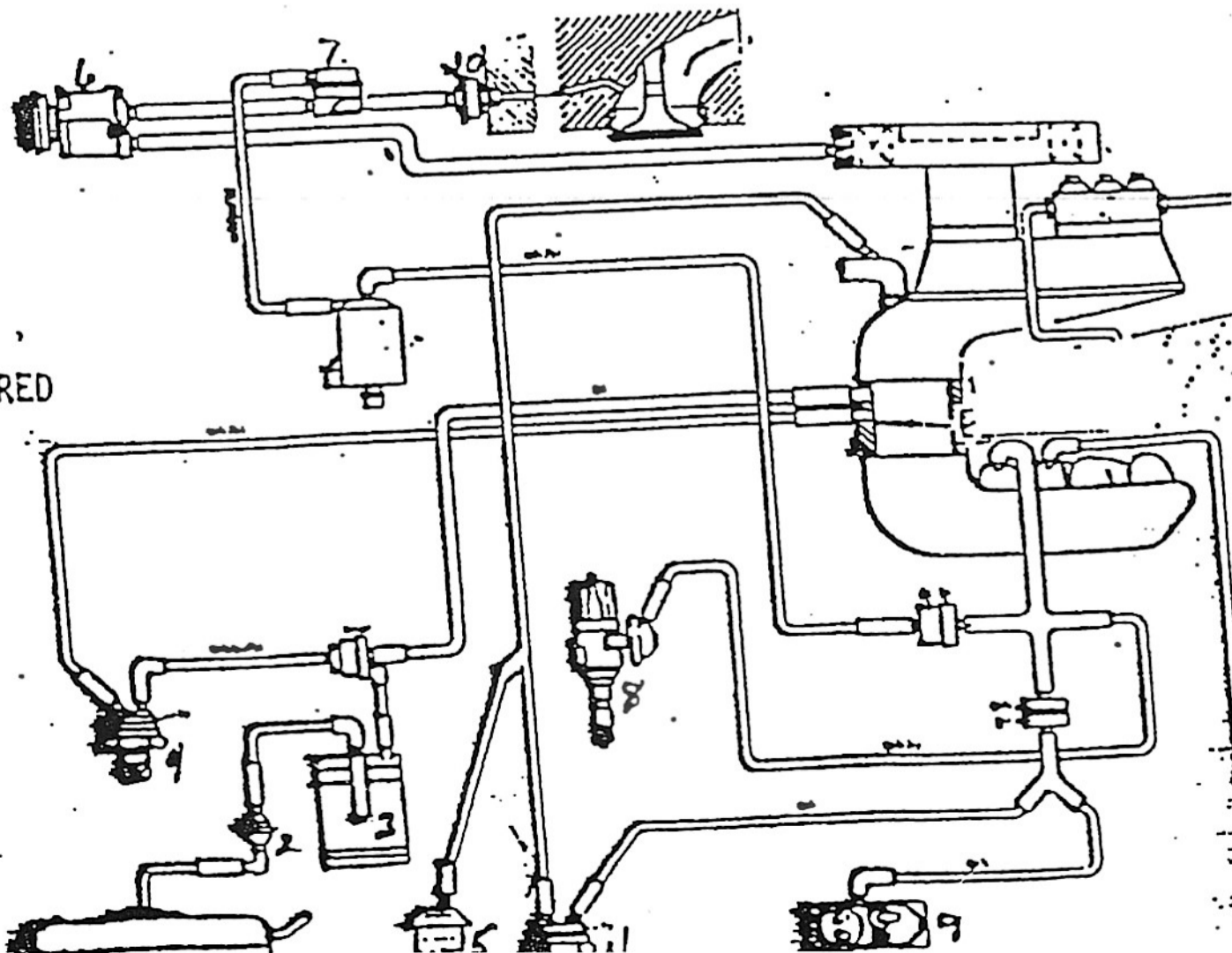

Note: ONLY CIRCLED NUMBERED ITEMS APPLY.

- 1. Fuel Tank
- 2. Check Valve
- 3. Charchol Canister
- 4. Temperature Switch
- 5. E.G.R.
- 6. Air Pump
- 7. Diverter Valve
- 8. Distributor
- 9. Warm-up Regulator



MY

MODEL

Maintenance Intervals: 1 - at 800 to 1,000 miles  
 2 - every 7,500 miles  
 3 - every 15,000 miles  
 4 - every 30,000 miles

Emission Control System Maintenance	MODEL			
	MY			
	1	2	3	4
Check valve clearance				
Replace air filter element				
Replace air filter element (engine and air pump)				x
Check condition of V-belt, adjust if necessary				x
Check condition of V-belt				
Replace spark plugs				x
Retorque bolts and nuts of exhaust flange	x			

MY

MODEL

Maintenance Intervals:

1 - at 800 to.	1,000 miles
2 - every	7,500 miles
3 - every	15,000 miles
4 - every	30,000 miles

Lubrication and General Maintenance of Engine	MODEL			
	MY			
	1	2	3	4
Change engine oil and filter	x	x		
Change manual transmission fluid				
Check level of manual transmission fluid, top up if necessary				
Change automatic transmission fluid, replace filter				x
Check level of autom. transmission fluid, top up if necessary	x		x	
Lubricate engine control linkages, check for easy motion and wear		x		

### LAMBDA COMPUTER WIRING DIAGRAM AND INSTALLATION INSTRUCTIONS

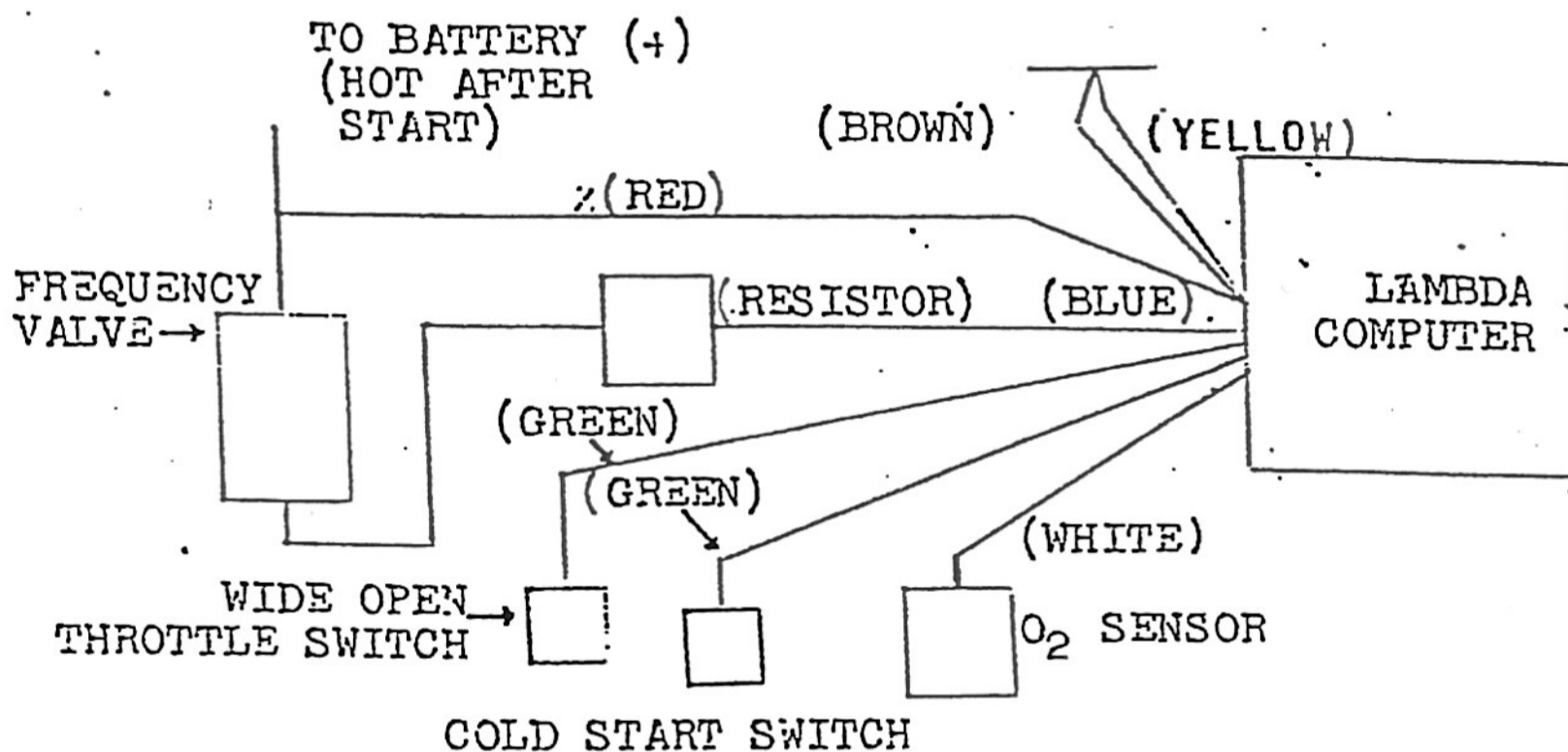

- 1) WHITE wire connects to oxygen sensor.
- 2) GREEN wires connect to either cold start switch or wide open throttle switch. Cold start switch is open when engine is hot.
- 3) BLUE wire goes to resistor, and then connects to frequency valve.
- 4) RED wire connects to other terminal on frequency valve and connects to battery (+) (hot after start).
- 5) BROWN and YELLOW wires connect together, and then to ground.
- 6) Computer should be located inside vehicle under dashboard but away from heater, ducts. DO NOT INSTALL IN ENGINE COMPARTMENT



# LIMITED WARRANTY

LIMITED WARRANTY NUMBER

2741

Provided for Warranty Holder (Vehicle Owner)	Limited Warranty Information
Name <u>Si</u> Address _____ City, State, Zip <u>Sonoma, Ca. 95476</u> Telephone No. _____	Limited Warranty Effective Date <u>3/22/01</u> Was a new odometer installed? YES _____ NO <u>X</u> Mileage registered on the original odometer (as of Limited Warranty Effective Date) <u>25,816</u> Term: For vehicles that have been in operation less than both 2 years and 24,000 miles as of the Limited Warranty Effective Date and Term under both Part 1 and Part 2 of this Limited Warranty is 5 years/50,000 miles (whichever occurs first). For vehicles that have been in operation for more than either 2 years or 24,000 miles as of the Limited Warranty Effective Date and Term under Part 1 of this Limited Warranty is 5 years/50,000 miles (whichever occurs first) and the Term under Part 2 is 2 years/24,000 miles (whichever occurs first). Note: Part 2 of this Limited Warranty does not apply to any vehicle that has been in operation for 60,000 miles or more as of the Limited Warranty Effective Date.
Provided By: ICI (Warrantor)	
Name of ICI <u>G&amp;K Auto Conversion</u> Address <u>3231 S. Standard Avenue</u> City, State, Zip <u>Santa Ana, Ca. 92705</u> Telephone No. <u>(714) 545-9503</u> ICI Account No. <u>003</u>	
Vehicle Information	
Year <u>1995</u> Make <u>Ferrari</u> Model <u>F355</u>	Vehicle Identification Number <u>ZFFPR4B000102248</u>

## Part 1: EMISSION CONTROL SYSTEM DEFECT LIMITED WARRANTY

For the term of either 5 years from the Limited Warranty Effective Date or 50,000 miles in addition to the mileage on the original odometer as of the Limited Warranty Effective Date (whichever occurs first), the ICI (Warrantor) warrants to the Warranty Holder and each subsequent purchaser during the term of this Limited Warranty that the Engine installed on the above-referenced vehicle has been equipped so as to conform on the Limited Warranty Effective Date with all U.S. emissions standards applicable on the Limited Warranty Effective Date and that the parts listed are free from defects in materials or workmanship which cause it not to meet those standards. The ICI (Warrantor), pursuant to this Limited Warranty, will pay for 100% of the Warranted Parts and 100% of the labor charges to repair or replace the Warranted Parts that fail during the Limited Warranty Term. Failures, other than those resulting from defects in material or workmanship, which arise solely as a result of owner abuse and/or lack of proper maintenance are not covered by this Limited Warranty.

### Part 1: DESCRIPTION OF PRIMARY EMISSION CONTROL SYSTEM DEFECT WARRANTED PARTS (ONLY PARTS LISTED BELOW ARE COVERED UNDER PART 1 OF THIS LIMITED WARRANTY)

WARRANTED PART	MANUFACTURER	PART NUMBER
Fuel Control Computer	<u>Ferrari</u>	<u>155006</u>
Computer Override	<u>N/A</u>	<u>N/A</u>
Catalytic Converter	<u>Ferrari</u>	<u>163198</u>
Oxygen Sensor	<u>Ferrari</u>	<u>155010</u>
Charcoal Canister	<u>Ferrari</u>	<u>16045</u>
Smog Pump/Bracket	<u>Ferrari</u>	<u>148049</u>
Frequency Valve	<u>N/A</u>	<u>N/A</u>
Fuel Inlet Restrictor	<u>Ferrari</u>	<u>153965</u>
_____	_____	_____
_____	_____	_____

Emission-related Hoses, Clamps, Belts, Pulleys, Tubes, Fittings, Sealing Devices, Mounting Hardware and Wiring Harnesses used on the above Warranted Parts.

# **G&K AUTOMOTIVE CONVERSION, INC.**

**3231 S. STANDARD AVE. SANTA ANA, CA 92705  
(714) 545-9503 (714) 545-7667**

## **G&K AUTOMOTIVE CONVERSION, INC. WARRANTY GASOLINE POWERED VEHICLES**

G&K Automotive Conversion, Inc. warrants to the original and each subsequent owner of a G&K Automotive Conversion, Inc. light-duty vehicle that (1) the vehicle was designed, built and equipped so as to conform at the time of sale to the original owner with the applicable regulations issued by the U.S. Environmental Protection Agency and (2) the vehicle is free from defects in materials and workmanship at the time of sale which would cause it not to conform with those regulations for a period of use of 5 years or 50,000 miles, whichever occurs first.

The 5 year/50,000 mile warranty period shall begin on the date the vehicle is delivered to the first purchaser or if the vehicle is first placed in service as a dealer demonstrator or G&K company vehicle prior to sale at retail, on the date the vehicle is first placed in such service. This 5 year/50,000 mile federal warranty period is in addition to any warranty coverage required under California regulations for California customers.

The emission control system of your 1995 FERRARI F355 was designed, built and tested, and the car is certified as being in conformity with Federal emission control regulations. Accordingly, it is recommended that any replacement parts used for maintenance, repair or replacement of the emission related components be Authorized Remanufactured Parts. The owner may elect to have maintenance, replacement or repair of the emission control devices and systems performed by any automotive repair establishment or individual, and may elect to use parts other than Authorized Remanufactured Parts for such maintenance, replacement or repair without invalidating this warranty: the cost of such service or parts, however will not be covered under this warranty.

Use of replacement parts which are not of equivalent quality may impair the effectiveness of the emission control systems. If other than Authorized Remanufactured Parts are used for maintenance, replacement or repair of components affecting emission control, the owner should obtain assurances that such parts are warranted by their manufacturer in performance and durability. G&K Automotive Conversion, Inc., however, assumes no liability under this warranty with respect to parts other than Authorized Remanufactured Parts.

Repairs covered by this warranty will be performed by an authorized dealer at his place of business with no charge for parts or labor (including diagnosis) using Authorized Remanufactured Parts for any part of the emission control system covered by this warranty found to be defective. In the case of an emergency when and where an authorized dealer is not available, repairs may be performed at any available service establishment. G&K Automotive Conversion, Inc. Will reimburse the owner for such repairs (including labor where required) that are covered under this warranty. Such reimbursements shall not exceed suggested retail prices for warranted parts replaced and labor charges based on recommended time allowances for warranty repairs at a geographically appropriate hourly labor rate.

Replaced parts and paid invoices must be presented for emergency repairs not performed at a dealer. Parts replaced under this warranty become the property of the warranty.

The attached list sets forth the emission related components covered by this emission control system warranty. You are advised to perform all recommended maintenance or repairs on your 1995 FERRARI F355. G&K Automotive Conversion, Inc. Will not deny a warranty claim solely because you have no record of maintenance, however, G&K Automotive Conversion, Inc. may deny a warranty claim if your failure to perform maintenance resulted in the failure of a warranted part. Receipts covering the performance of regular maintenance should be retained in the event questions arise in relation to vehicle maintenance. The receipts should be transferred to each subsequent owner.

This warranty does not cover:

1. Malfunctions in any part caused by any of the following: misuse, improper adjustments, modifications, alteration, tampering disconnection and improper or inadequate maintenance, or use of leaded gasoline (for catalyst equipped vehicles).
2. Damage resulting from accident, acts of nature or other events beyond the control of G&K Automotive Conversion, Inc.
3. The repair or replacement of warranted parts which are scheduled for replacement prior to 50,000 miles (such as spark plugs or air filter) once these parts have been replaced at the first recommended replacement interval as part of regular maintenance service.
4. Loss of time, inconvenience, loss of use of the vehicle, or other incidental or consequential damages.
5. Any car on which the odometer mileage has been altered so that the vehicle's actual mileage cannot be readily determined.
6. Repairs consisting solely of adjustments to idle speed, or valve clearance, or any combination thereof.

WITH RESPECT TO EMISSION SYSTEMS, THIS WARRANTY IS EXPRESSLY IN LIEU OF ALL OTHER WARRANTIES AND REPRESENTATIONS, EXPRESSED OR IMPLIED, INCLUDING, BUT NOT LIMITED TO, IMPLIED WARRANTY OF



MERCHANTABILITY OF FITNESS FOR A PARTICULAR PURPOSE, AND OF ALL OTHER OBLIGATIONS OR LIABILITIES ON THE PART OF THE WARRANTOR. G&K AUTOMOTIVE CONVERSION, INC. NEITHER ASSUMES NOR AUTHORIZES ANY OTHER PERSON TO ASSUME FOR IT ANY OTHER LIABILITY IN CONNECTION WITH SUCH EMISSION SYSTEMS.

For further information, you may contact:

G&K Automotive Conversion, Inc.  
3231 S. Standard Avenue  
Santa Ana, CA 92705  
Tel: (714) 545-9503  
Fax: (714) 545-7667

G & K AUTOMOTIVE CONVERSION, INC.  
 3231 S. STANDARD AVE.  
 SANTA ANA, CA 92705

**INVOICE**

5587

PHONE (714) 545-9503  
 FAX (714) 545-7667

TO

86  
 SONOMA, CA 95476

TERMS:

DATE

3/16/01

CUSTOMER ORDER NO.

7169

SALESPERSON

GG

VIA

NIK # 0139945

QUANTITY	DESCRIPTION	PRICE	AMOUNT
	CUSTOMS ENTRY FEE	\$300.00	\$300.00
	CUSTOMS DUTY (SUBJECT TO LIQUIDATION)	\$1,759.44	\$1,759.44
	BONDING PREMIUM	\$1,861.83	\$1,861.83
	BOND APPLICATION FEE	\$250.00	\$250.00
	BOND RELEASE FEE	\$153.15	\$153.15
	EPA PROCESSING FEE	\$620.61	\$620.61
	EPA/DOT WARRANTY	\$350.00	\$700.00
	MESSENGER SERVICE	\$40.00	\$40.00
	SPECIAL HANDLING SERVICES	\$50.00	\$50.00
	DEMURRAGE	\$169.00	\$169.00
	TOWING FROM PORT TO G & K	\$85.00	\$85.00
	DEVANNING	\$350.00	\$350.00
	CARB CERTIFICATE	\$350.00	\$350.00
	TOTAL		<u>\$6,689.03</u>

THANK YOU

 To Reorder:  
 800-225-5380 or nebs.com

# G & K AUTOMOTIVE CONVERSION, INC.

3231 S. STANDARD AVE, SANTA ANA, CA 92705

(714) 545-9503 FAX (714) 545-7667

Parts covered under G & K Automotive Conversion, Inc., Motor vehicle emission performance warranty.

The following is a list of all the emission related components on this **1995 FERRARI F355** VIN# **ZFFPR48B000102248** This list includes both parts installed by G & K as well as any OEM parts which may or may not have been installed by the manufacturer.

<u>PART</u>	<u>PART #</u>	<u>OEM/ICI</u>	<u>COVERAGE PERIOD</u>
CATALYTIC CONVERTER	163198	ICI	5/50
OXYGEN SENSOR	155010	ICI	5/50
ELECTRONIC EMISSION CONTROL UNIT	155006	OEM	5/50
FUEL FILLER RESTRICTOR	153965	OEM	5/50
UNLEADED ONLY FUEL LABELS	139715	ICI	5/50
VAPOR STORAGE CANISTER	16045	OEM	5/50
CANISTER PURGING HOSE	N/A	N/A	N/A
CANISTER PURGING PUMP	N/A	N/A	N/A
ROLLOVER VALVE	N/A	N/A	N/A
FREQUENCY VALVE	N/A	N/A	N/A
EGR VALVE	N/A	N/A	N/A
THERMAL VACCUM SWITCH	N/A	N/A	N/A
SMOG PUMP/ BRACKET	148049	OEM	5/50
DIVERTER VALVE	147390	OEM	5/50
A.I.R SYSTEM	148049	OEM	5/50
PULSE AIR VALVE	170442	OEM	2/24
FUEL PRESSURE CONTROL REGULATOR	167371	OEM	2/24
FUEL DISTRIBUTOR	167371	OEM	2/24
AIR FLOW SENSOR	0280217506	OEM	2/24
FUEL INJECTORS	169421	OEM	2/24
IGNITION DISTRIBUTOR	N/A	N/A	N/A
TIMING ADVANCE/RETARD SYSTEM	N/A	N/A	N/A
IGNITION WIRES AND COIL	N/A	N/A	N/A
SPARK PLUGS	169423	OEM	2/24
EXHAUST MANIFOLD	160010	OEM	2/24





**USED MODIFIER-CERTIFIED MOTOR VEHICLE  
CERTIFICATE OF CONFORMANCE**

THIS VEHICLE CONFORMS TO APPLICABLE STATE OF CALIFORNIA  
REGULATIONS FOR THE 1995 MODEL YEAR.

C of C Number UDI 1657

VIN ZFFPR48B000102248 MAKE FERRARI ODOMETER 25,175 Mi.  
 MODEL F-355 MODEL YEAR 1995 DATE OF MANUFACTURE 05/31/95  
 CUSTOM'S ENTRY # 692-0139945-3 DATE OF ENTRY 1/2001 PORT OF ENTRY 2704  
 AGE OF VEHICLE AT ENTRY INTO CALIFORNIA 5 YRS. 8 MOS. DECLARED VALUE \$ 62061  
 MODIFIER'S NAME G & K AUTOMOTIVE CONV. MODIFIER'S PHONE (714)545-9503  
 MODIFIER'S ADDRESS 3231 S. STANDARD AVE.  
SANTA ANA CA 92705  
 MODIFIER'S AUTOMOTIVE REPAIR DEALER REGISTRATION NUMBER AC204045  
 DATE EMISSION SYSTEM MODIFICATION COMPLETED 02/05/01

*I certify, under penalty of perjury under the laws of the State of California, that all information on this document is correct and that the above-described vehicle has been modified to conform with the requirements of Chapter 6, Part 5, Division 26, of the California Health and Safety Code and that the above vehicle is in compliance with applicable laws and regulations. I further certify, under penalty of perjury under the laws of the State of California, that I have received the U.S. Department of Transportation bond release for safety for the above-described vehicle.*

SIGNATURE OF OWNER OR MGR. OF MODIFYING FACILITY \_\_\_\_\_

LICENSED LABORATORY'S E.O.# T102-12 E.O. DATE OF ISSUANCE 07/31/2000  
 LICENSED LABORATORY'S NAME CALIFORNIA ENVIRONMENTAL ENGINEERING  
 LICENSED LABORATORY'S ADDRESS 3231 S. STANDARD AVE.  
SANTA ANA CA 92705

*I certify, under penalty of perjury under the laws of the State of California, that the vehicle described above has been inspected and emission tested in accordance with the federal test procedures, Title 40, Code of Federal Regulations, Part 86, Subpart B, as they existed on July 1, 1985 by the licensed laboratory described above, that the emission control system components listed below were installed and functional at the time the test was performed, that the owner's manual with the vehicle contains a true and accurate description of the emission control system's functioning and maintenance, that the vehicle has been inspected and complies with the required specifications for fillpipes and opening of fuel tanks, tune-up labels, idle air/fuel adjustments, and any other applicable requirements specified under the "California Certification Procedures for 1975 and Later Model-Year Used Modifier-Certified Motor Vehicles" and that the vehicle has been emission tested and conforms with the applicable California emission standards for the vehicle model-year. I further certify under penalty of perjury under the laws of the State of California, that the emission control system installed on the vehicle has no obvious engineering or installation defects at the time of inspection and that a detailed written description of the vehicle inspection is attached to this document.*

SIGNATURE OF LICENSED LABORATORY MANAGER \_\_\_\_\_

CERTIFICATE OF CONFORMANCE DATE OF ISSUANCE 03/02/2001

**CRITICAL EMISSION CONTROL COMPONENTS**

Emission Control Component	Vendor	Part Number
1. Catalytic Converter	<u>FERRARI</u>	<u>163198</u>
2. O2 Sensor	<u>FERRARI</u>	<u>155010</u>
3. Electronic Control Unit	<u>FERRARI</u>	<u>155006</u>
4. EGR System	<u>N/A</u>	<u>N/A</u>
5. Air Injection System	<u>FERRARI</u>	<u>148049</u>
6. Other CANISTER	<u>FERRARI</u>	<u>16045</u>

**EXHAUST AND EVAPORATIVE EMISSIONS**

	HC	CO	NOx	Evap.	Part
Emission Standards	<u>0.25</u>	<u>3.4</u>	<u>0.4</u>	<u>2.00</u>	<u>N/A</u>
Emission Test Results	<u>0.11</u>	<u>0.8</u>	<u>0.2</u>	<u>0.63</u>	<u>N/A</u>

**IMPORTANT: ORIGINAL (WHITE) COPY OF THIS DOCUMENT MUST ACCOMPANY DMV APPLICATION FOR REGISTRATION**

*The owner's copy of this document is to be kept in the vehicle for which issued. It need not be displayed.*

**STATE OF CALIFORNIA**

**Consumer Assistance and Referee Center**

**IRVINE, CA**

**Invoice Number 34370**

**Site Number: XF799202 1-800-622-7733**

March 02, 2001

**Customer:**

CEE

**HomePhone:**

(714) 545-7777

**Vehicle Year:** 1995

**Make:** FERRA

**Model:** F-355

**Address:**

3231 S STANDARD AVE

**Business Phone:**

( ) -

**License or VIN:** ZFFPR48B000102248

**Odometer Reading:** 25,201

**City:** SANTA ANA

**State:** CA **ZIP:** 92705

**Service Description**

**Referee Action**

**Test Amount: \$30.00**

**Total Estimate: \$38.25 (Smog Check Inspection and Certificate)**

**Smog Certificate: \$8.25**

I hereby authorize the above work to be done, which may include minor repairs and hereby grant you and/or your employees permission to operate the vehicle herein described on streets, highways or elsewhere for the purpose of testing and/or inspection. An express mechanic's lien is hereby acknowledged on the vehicle to secure the amount of the inspection and/or the smog certificate thereto. I will not hold CCF or any of its employees or subcontractors responsible for loss or damage to vehicle or articles left in vehicle in case of fire, theft, accident or any other cause beyond our control. If action is brought to collect amounts due under this agreement, I agree to pay reasonable attorney's fees. Customer acknowledges receipt hereof.

**Work Authorized by: x**

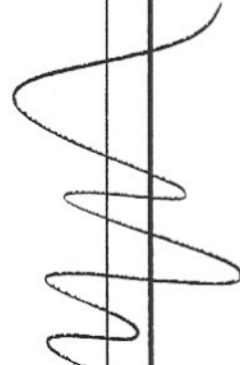

**ESTIMATE COPY**



U.S. Department  
of Transportation  
**National Highway  
Traffic Safety  
Administration**

400 Seventh St., SW  
Washington, DC 20590

7169  
X

FEB-28-2001

In Reply Refers To:  
NSA-32CUS  
101-740

G & K AUTOMOTIVE  
3231 S. STANDARD AVE  
SANTA ANA, CA 92705

Dear Importer:

The National Highway Traffic Safety Administration (NHTSA) acknowledges receipt of a certificate of compliance and payment of the bond processing costs for the vehicle imported on the following Customs entry:

Customs Entry No. & Date:	69201399453 JAN-03-2001
Port code:	2704
Vehicle Make & Model:	FERRARI 355
Vehicle Identification No:	ZFFPR48B000102248

The bond issued pursuant to 49 CFR 591.6(c) to ensure that the vehicle is brought into compliance with all applicable Federal motor vehicle safety standards may be released. This bond release does not constitute agreement by NHTSA that the vehicle, in fact, is in conformance with all applicable Federal motor vehicle safety standards since actual conformance with many requirements is determinable only by compliance testing. Please be advised that NHTSA reserves the right to make an actual compliance inspection of the vehicle at a future date to verify the accuracy of the Registered Importer's certificate.

Sincerely,

Marilynne Jacobs, Director  
Office of Vehicle Safety Compliance

Z30166

RFM





BUREAU OF AUTOMOTIVE REPAIR  
State of California Smog Check Referee Center

Date: 2-Mar-2001  
VIN or License #: 9331846  
Year Make: 97 BMW

Model: F355

The technician has noted the following pre-existing damage on your vehicle. The signatures of the technician and the consumer acknowledging any pre-existing damage to the vehicle are required. Provide a copy to the consumer and attach the original with the VIR.

Lane Tech: SEAN 

Consumer: CEE 

PLEASE PUT A CHECK MARK ACKNOWLEDGING THE FOLLOWING DAMAGE

Yes  No

Please specify the extent and location of any external body damage.

Dent on trunk  
Scratch on door

Yes  No

Please specify the extent and location of any interior body damage.

MISCELLANEOUS

Yes  No

Please specify other damage not covered above.

Yes  No

No pre-existing damage

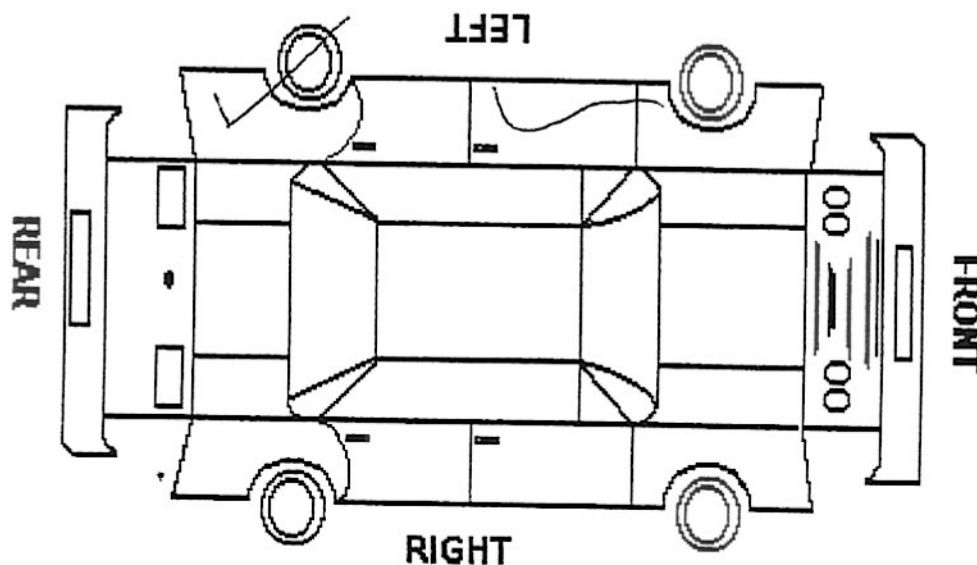

CALIFORNIA AIR RESOURCES BOARD  
 USED DIRECT IMPORT VEHICLE PROGRAM  
 Written Description of Vehicle Inspection  
 As Required By The Certificate of Conformance

1 IMPORTER'S

Name \_\_\_\_\_  
 Address \_\_\_\_\_ 95476

2 LICENSED LABORATORY'S

Name California Environmental Engineering  
 Address 3231 S. Standard Ave. Santa Ana 92705

3 CERTIFICATE OF CONFORMANCE NO 1657 Date Issued 03/02/2001

4 VEHICLE IDENTIFICATION NUMBER ( VIN ) ZFFPR48000102248

5 VIN Imprinted On Catalytic Converter (yes) - (no) Yes  
 If No Explain \_\_\_\_\_

6 VEHICLE YEAR 1995 MAKE FERRARI Model F355

7 OWNER'S MANUAL For Retrofit Systems Provided to owner Yes

8 VEHICLE EQUIPMENT INSTALLATION CHECKLIST

( Checks indicate Installed Equipment Or Tests Completed)

- Lambda Control Unit-Computer \_\_\_\_\_ ( X )
- Oxygen Sensor \_\_\_\_\_ ( X )
- Pre Catalytic Converter (No. Installed) \_\_\_\_\_ ( )
- Catalytic Converter ( Indicate no. installed ) 2 ( X )
- Single Bed Cat.( \_\_\_\_\_ )Dual Bed Cat.( \_\_\_\_\_ ) 3 Way Cat. \_\_\_\_\_ ( X )
- Warm -Up Regulator , If Modified \_\_\_\_\_ ( )
- Air Pump \_\_\_\_\_ ( X )
- Thermal Vacuum Switch (TVS) \_\_\_\_\_ ( )
- Air Injection System \_\_\_\_\_ ( X )
- Air Diverter Valve \_\_\_\_\_ ( X )
- Unleaded Fuel Restrictor \_\_\_\_\_ ( X )
- Unleaded Fuel Label Near Fill Pipe Or On Gas Cap \_\_\_\_\_ ( X )
- Unleaded Fuel Label On Dashboard Or Instrument Panel \_\_\_\_\_ ( X )
- Frequency Valve (Describe Use ) \_\_\_\_\_ ( )
- Exhaust Gas Recirculation (EGR) System \_\_\_\_\_ ( )
- Ignition Distributor , if Modified \_\_\_\_\_ ( )
- Flashback Valve \_\_\_\_\_ ( )
- Electric Pump Timer \_\_\_\_\_ ( )
- Pressure Relief Valve \_\_\_\_\_ ( )
- Positive Crankcase Ventilation (PCV) \_\_\_\_\_ ( X )
- Charcoal Evaporative Canister \_\_\_\_\_ ( X )
- One Way Valve ( Describe Use ) inline between tank & Canister ( X )
- CVS Test Performed \_\_\_\_\_ ( X )
- Other Dynamometer Tests Performed \_\_\_\_\_ ( )
- Identify Other Tests \_\_\_\_\_
- Emission Control Information Label \_\_\_\_\_ ( X )
- Label Location Rear Right Fender Wall
- Vacuum Hose Routing Diagram \_\_\_\_\_ ( X )
- Diagram Location Rear Right Fender Wall
- Other \_\_\_\_\_ ( )

9 Printed Name And Title Of Licensed Laboratory Person \_\_\_\_\_

Filling In this Form Waneis Wartan  
Asst. Mgr.

Date This Form Completed 03/02/2001



V639868

# APPLICATION FOR TITLE OR REGISTRATION

DMV USE ONLY	
C/S DL #/STATE	
TECH INITIALS	

VEHICLE/HULL IDENTIFICATION NUMBER <b>ZFFPR48B000102248</b>	MAKE OF VEHICLE OR VESSEL BUILDER <b>FERRARI 355</b>
--	---

776 0020 00125 0020 634 APR 10 2001 25 0020 800

## 1. OWNER INFORMATION (Please print true full name or lessor/business name)

LAST NAME OF LESSOR OR BUSINESS NAME	FIRST NAME	MIDDLE NAME	CALIFORNIA DRIVER LICENSE OR ID NUMBER	
LAST NAME, OR LESSEE	FIRST NAME	MIDDLE NAME	CALIFORNIA DRIVER LICENSE OR ID NUMBER	
LAST NAME, OR LESSEE	FIRST NAME	MIDDLE NAME	CALIFORNIA DRIVER LICENSE OR ID NUMBER	
RESIDENCE OR BUSINESS ADDRESS (If Different From Above)			CITY	STATE
MAILING ADDRESS (If Different From Above)			CITY	STATE
LESSEE ADDRESS (If Different From Above)			CITY	STATE
ADDRESS WHERE TRAILER IS LOCATED (If Different From Above)			CITY	STATE

## 2. TITLE HOLDER INFORMATION (Do NOT reenter owners name) If "NONE", so print

NAME OF BANK/FINANCE COMPANY OR INDIVIDUAL <b>NONE</b>	ELECTRONIC TITLE NUMBER
BUSINESS OR RESIDENCE ADDRESS	STATE
MAILING ADDRESS (If Different From Above)	STATE

## 3. COST AND OPERATION INFORMATION (Purchase price does not include sales tax, insurance, finance charges, or warranty.)

MILES/KILOMETERS AT TIME OF ENTRY: 125,100.00 (no tenths)  Miles  Kilo.  is the actual mileage  is not the actual mileage  mileage exceeds the odometer mechanical limit

DATE VEHICLE ENTERED CALIFORNIA Mo. <u>March</u> Day <u>24</u> Yr. <u>2001</u>	PURCHASE PRICE OR MARKET VALUE (IF GIFT, OR TRADE) <u>\$62,061</u>
DATE YOU PURCHASED OR ACQUIRED VEHICLE Mo. <u>August</u> Day <u>31</u> Yr. <u>2000</u>	DATE YOU WENT TO WORK IN CALIFORNIA OR BECAME A RESIDENT Mo. _____ Day _____ Yr. <u>1982</u> (whichever occurred first)

- A. Will this vehicle be used to carry people for hire (taxi, bus, etc.)?  Yes  No
  - B. Are you now or have you within the last three years been on active duty with the U.S. Armed Forces?  Yes  No
  - C. When you acquired this vehicle were you on active duty in the U.S. Armed Forces?  Yes  No
- If yes, print name of state or country where stationed \_\_\_\_\_

## 4. OWNER(S) SIGNATURE(S)

The registered owner mailing address is valid, existing, and an accurate mailing address. I consent to receive service of process at this mailing address pursuant to §1808.21 of the Vehicle Code.

**I certify under penalty of perjury under the laws of the State of California that the foregoing is true and correct.**

OWNER'S SIGNATURE <b>X</b>	DATE <u>4/10/2001</u>	DAYTIME TELEPHONE NUMBER <u>(7...)-6</u>
OWNER'S SIGNATURE <b>X</b>	DATE	DAYTIME TELEPHONE NUMBER



1-11

## FAX TRANSMITTAL COVER

NUMBER OF PAGES (including cover sheet): 2	DATE: 4/17/01
ORIGINAL: <input type="checkbox"/> To Follow by Regular Mail	<input checked="" type="checkbox"/> Will Not Follow
TO: Silvano Payne	FROM: Heather Newman
FIRM/ADDRESS:	ADDRESS:
TELEPHONE NUMBER: ( )	TELEPHONE NUMBER: (916) 445-9524
FAX NUMBER: (714) 324-2491	FAX NUMBER: (916) 324-2491
CC:	

- The attached document does not contain any confidential information.
- The attached document contains confidential information.\*
- The attached document contains confidential information and is subject to attorney/client privilege.\*

COMMENTS:

\*Notice: The information contained in the attached facsimile message is private, confidential, or legally privileged. It is intended ONLY for the use of the person(s) specifically named herein as sender and recipient(s) of the communication. Any retention, display, dissemination, distribution, disclosure, publication or copying of the contents of the attached message by individuals OTHER than the sender or recipient of the said communication is strictly prohibited. If you have received this facsimile message in error, please immediately notify the SENDER (the State Board of Equalization) at sender's telephone number listed above, then immediately destroy or return the entire facsimile message by first class mail, without copying the message, and without disclosing its contents to any person other than the sender or recipient. Persons who copy or disclose such confidential information are subject to applicable legal penalties.

# APPLICATION FOR TITLE OR REGISTRATION

V034868

DMV USE ONLY	
O/S DL #/STATE	
TECH INITIALS	

VEHICLE/HULL IDENTIFICATION NUMBER <b>ZFFPR 48 B 000102248</b>	MAKE OF VEHICLE OR VESSEL BUILDER <b>FERRARI 355</b>
---	---

**1. OWNER INFORMATION (Please print true full name or lessor/business name)**

LAST NAME OR LESSOR OR BUSINESS NAME <b>D...</b>	FIRST NAME	MIDDLE NAME	CALIFORNIA DRIVER LICENSE OR ID NUMBER <b>C ... 15</b>	
LAST NAME, OR LESSEE	FIRST NAME	MIDDLE NAME	CALIFORNIA DRIVER LICENSE OR ID NUMBER	
LAST NAME, OR LESSEE <input type="checkbox"/> AND <input type="checkbox"/> OR	FIRST NAME	MIDDLE NAME	CALIFORNIA DRIVER LICENSE OR ID NUMBER	
RESIDENCE OR BUSINESS ADDRESS (If Different From Above)	APT./SPACE NO.	CITY <b>SONOMA</b>	STATE <b>CA</b>	ZIP CODE <b>95476</b>
MAILING ADDRESS (If Different From Above)	APT./SPACE NO.	CITY	STATE	ZIP CODE
LESSEE ADDRESS (If Different From Above)	APT./SPACE NO.	CITY	STATE	ZIP CODE
ADDRESS WHERE TRAILER IS LOCATED (If Different From Above)		CITY	STATE	ZIP CODE

**2. TITLE HOLDER INFORMATION (Do NOT reenter owners name) If "NONE", so print**

NAME OF BANK/FINANCE COMPANY OR INDIVIDUAL <b>NONE</b>	ELECTRONIC TITLE NUMBER			
BUSINESS OR RESIDENCE ADDRESS	APT./SPACE NO.	CITY	STATE	ZIP CODE
MAILING ADDRESS (If Different From Above)	APT./SPACE NO.	CITY	STATE	ZIP CODE

**3. COST AND OPERATION INFORMATION (Purchase price does not include sales tax, insurance, finance charges, or warranty.)**

MILES/KILOMETERS AT TIME OF ENTRY  
**125,000** (no tenths)  Miles  Kilo.  is the actual mileage  is not the actual mileage  mileage exceeds the odometer mechanical limit

DATE VEHICLE ENTERED CALIFORNIA Mo. <b>March</b> Day <b>24</b> Yr. <b>2001</b>	PURCHASE PRICE OR MARKET VALUE (IF GIFT, OR TRADE) <b>\$62,061</b>
DATE YOU PURCHASED OR ACQUIRED VEHICLE Mo. <b>August</b> Day <b>31</b> Yr. <b>2000</b>	DATE YOU WENT TO WORK IN CALIFORNIA OR BECAME A RESIDENT Mo. _____ Day _____ Yr. <b>1982</b> (whichever occurred first)

- A. Will this vehicle be used to carry people for hire (taxi, bus, etc.)?  Yes  No
- B. Are you now or have you within the last three years been on active duty with the U.S. Armed Forces?  Yes  No
- C. When you acquired this vehicle were you on active duty in the U.S. Armed Forces?  Yes  No
- If yes, print name of state or country where stationed \_\_\_\_\_

**4. OWNER(S) SIGNATURE(S)**

The registered owner mailing address is valid, existing, and an accurate mailing address. I consent to receive service of process at this mailing address pursuant to §1808.21 of the Vehicle Code.

**I certify under penalty of perjury under the laws of the State of California that the foregoing is true and correct.**

OWNER'S SIGNATURE <b>X</b>	DATE <b>4/10/2001</b>	DAYTIME TELEPHONE NUMBER <b>(707) 939-9306</b>
OWNER'S SIGNATURE <b>X</b>	DATE	DAYTIME TELEPHONE NUMBER ( )

BOE-106 (FRONT) REV. 11 (2-98)

**VEHICLE/VESSEL USE TAX INFORMATION**

STATE OF CALIFORNIA  
BOARD OF EQUALIZATION

NAME OF CLAIMANT <i>Pauline</i>		TELEPHONE NO. <i>170</i>	
ADDRESS (street, city, state, zip code) <i>SONOMA, CA 95476</i>			
NAME OF SELLER <i>FERRI AUTO - MR ENZO FERRI</i>		TELEPHONE NO. <i>(059) 217 561</i>	
ADDRESS (street, city, state, zip code) <i>P.le RISORGIMENTO, 1, MODENA 41100</i>			
MAKE OF: <input checked="" type="checkbox"/> Vehicle <input type="checkbox"/> Vessel		YEAR <i>1995</i>	
DATE YOU APPLIED FOR CALIFORNIA REGISTRATION <i>4/10/01</i>		REGISTRATION OR LICENSE NO.(s) <i>N/A</i>	ENGINE OR I.D. NO.(s) <i>ZFFPR48B00102248</i>
DATE VEHICLE/VESSEL WAS DELIVERED <i>3/24/01</i>		DATE VEHICLE/VESSEL ENTERED CALIFORNIA <i>01/03/01</i>	DMV SUSPENSE RECEIPT NO. <i>V639868</i>
DATE YOU BECAME RESIDENT OF CALIFORNIA <i>1979</i>		DATE EMPLOYED IN CALIFORNIA <i>1979</i>	
WAS VEHICLE/VESSEL REGISTERED OUTSIDE THIS STATE BEFORE IT WAS BROUGHT TO CALIFORNIA? IF YES, WHERE? <i>REGISTERED TO DEALER IN ITALY</i>			
FOR MOBILEHOMES ONLY:	MODEL	YEAR	MOBILEHOME MANUFACTURER
			PURCHASE PRICE
			SIZE

I HEREBY CLAIM AN EXEMPTION FROM THE CALIFORNIA USE TAX FOR THE FOLLOWING REASON:

*- I bought the car in Italy in August 2000 and it was used by me in Italy for over 90 days. The car was shipped to California after delivery to the shipper on December 1st 2000.*

I hereby certify that the above statements, to the best of my knowledge and belief, are true and correct.

SIGNATURE OF CLAIMANT <i>[Signature]</i>	DATE <i>5/8/01</i>
---	-----------------------

Take or mail this form to a local Board office (refer to the government pages of your telephone directory or call the Board's Information Center at 1-800-400-7115 for the address of the office nearest you). Be sure to include any required documentation.



~~SECRET~~

5/8/01

To HEATHER NEWMAN

FROM

Dear Heather,

Thanks for faxing the application papers. It took a while to get the originals from Italy but hopefully this is all you will need.

Pages following:

1. Application Form
2. Entry Summary (Dept. of Treasury)
3. Original Invoice (Terri Auto)
4. Shipping Document (Emil Peel)
5. Letter from Uncle (with Translation)
6. VISA charges in Europe (4 pages).  
September to November.

Yours sincerely

NI  
11 12



STATE OF CALIFORNIA  
 BOARD OF EQUALIZATION  
 SALES AND USE TAX DEPARTMENT

No. 426677

**CERTIFICATE OF VEHICLE, MOBILEHOME OR  
 COMMERCIAL COACH USE TAX CLEARANCE**

FOR COMPLETION OF REGISTRATION ONLY  
 Under the Sales and Use Tax Law

NAME OF APPLICANT	
MAKE OF VEHICLE/YEAR MODEL Ferrari/1995	LICENSE OR DECAL NO. VIN OR SERIAL NO. ZFFPR48B000102248

- TO:  DEPARTMENT OF MOTOR VEHICLES  
 TO:  DEPARTMENT OF HOUSING AND COMMUNITY DEVELOPMENT

Under section 6422.1 of the Revenue and Taxation Code, it is hereby certified that the above-named applicant is exempt from use tax obligations as a prerequisite for the registration of the above-described vehicle, mobilehome, or commercial coach. This certificate allows registration of the above-described vehicle, mobilehome, or commercial coach without payment of California use tax at the time of registration. It does not exempt the applicant from the obligation to pay any use tax that may be due.

DATE ISSUED May 18, 2001	BY <i>Ada Nakamura</i>	ISSUING OFFICE HQ Consumer Use Tax Section
-----------------------------	---------------------------	---

ANY ERASURE OR ALTERATION OF THIS CERTIFICATE WILL MAKE IT VOID

# Smog Check Vehicle Inspection Report (VIR)

## Vehicle Information

Test Date/Time: 03/02/2001 @ 14:26

Model-Year: 1995	Make: FERRARI	Model: F355
License: N	State: Unknown	VIN: ZFFPR48B000102248
Engine Size: 3.5 L	Type: Passenger	Transmission: Manual
GVWR: N/A	Test Weight: N/A	Cylinders: 8
Odometer: 25201	Certification: California	VLT Record #: 14345
Fuel-Type: Gasoline	Exhaust: Dual	Inspection Reason: Initial Registration
BAR #: N5306465	Engine Year: 1995	Engine Make: FERRA

## Overall Test Results

**By keeping your vehicle well-maintained, you've passed your enhanced Smog Check and are helping California reach its goal of removing an extra 100 tons of smog-forming emissions from the air every day.**

Comprehensive Visual Inspection: PASS    Functional Check: PASS    Emissions Test: PASS

Smog Check Certificate Number: EB708720  
DMV ID Number: **4240B927E488**

Your Smog Check certificate will be electronically transmitted to DMV.  
Your certificate is valid for 90 days from date of issuance.  
Please keep this copy for your records.

## Emission Control Systems Visual Inspection/Functional Check Results

(Visual/Functional tests are used to assist in the identification of oxides of nitrogen, crankcase and cold start emissions which are not measured during the Idle test)

<u>Result</u>	<u>ECS</u>	<u>Result</u>	<u>ECS</u>	<u>Result</u>	<u>ECS</u>
PASS	PCV	N/A	Thermostatic Air Cleaner	PASS	Fuel Evaporative Controls
PASS	Catalytic Converter	PASS	Air Injection	PASS	System Malfunction Light
N/A	Exhaust Gas Recirculation	PASS	Spark Controls	PASS	Carb./Fuel Injection
PASS	Wiring to Sensors	PASS	Vacuum Lines to Sensors/ Switches	PASS	Other Emission Related Components
PASS	Fillpipe Restrictor	N/A	Ignition Timing:	PASS	Oxygen Sensor
PASS	Fuel Cap Integrity Test				

## Idle Emission Test Results

Test	RPM	%CO <sub>2</sub>		HC (PPM)			CO (%)			Results
		MEAS	MEAS	MAX	AVE	MEAS	MAX	AVE	MEAS	
Idle	1065	13.7	1.5	100	17	29	1.00	0.00	0.04	PASS
2500 RPM	2668	13.8	1.4	130	12	17	1.00	0.10	0.01	PASS

MAX = Maximum Allowable Emissions

AVE = Average Emissions For Passing Vehicles

MEAS = Amount Measured

## Smog Check Inspection Station Information

Consumer Assistance Referee Center  
12 Hammond Dr. Unit # 203, Irvine, CA 92618  
1 800 622-7733  
Station Number: XF799202

Technician Name/Number: KENNEDY RUSSELL OWEN/EA121911  
Repair Tech Name/Number:  
Software Version/EIS Number: 9952/ES986948

I certify, under penalty of perjury, under the laws of the State of California, that I performed the inspection in accordance with all bureau requirements, and that the information listed on this vehicle inspection report is true and accurate.

3.2.01

Date



Technician's Signature





# VERIFICATION OF VEHICLE NOT TO BE COMPLETED BY APPLICANT

This form must be completed in full by an authorized DMV representative, California licensed vehicle verifier, authorized auto club, or peace officer.

**WARNING:** Alterations or erasures will void this form.

LICENSE PLATES ON VEHICLE <input checked="" type="checkbox"/> None <input type="checkbox"/> Dealer <input type="checkbox"/> Temporary Permit	LICENSE PLATE NUMBER	STATE	EXP. DATE
---	----------------------	-------	-----------

VEHICLE IDENTIFICATION NUMBER (VIN) ZFFPRAB B000102248			
ENGINE NUMBER (MOTORCYCLES ONLY)	MAKE Ferrari	BODY TYPE CV	MODEL YEAR 1995
AXLES 2	MOTIVE POWER (FUEL) G	EST. WEIGHT (TRAILERS)	MODEL OR SERIES F355 Spider
		FOR CMP/CCH Length _____ Width _____	

<b>VIN Location:</b> <input type="checkbox"/> Visible through windshield <input type="checkbox"/> Body—Left (driver side) <input checked="" type="checkbox"/> Body—Right <input type="checkbox"/> Engine compartment	<input type="checkbox"/> Trunk <input type="checkbox"/> Frame <input type="checkbox"/> Other: _____	<b>Attached by:</b> <input type="checkbox"/> Not visible <input type="checkbox"/> Rosette rivets <input checked="" type="checkbox"/> Round rivets <input type="checkbox"/> Screws	<input type="checkbox"/> Adhesive <input type="checkbox"/> Not applicable <input type="checkbox"/> Other: _____
--	---	---	---

<b>Type:</b> <input checked="" type="checkbox"/> Metal plate <input type="checkbox"/> Stamped on body	<input type="checkbox"/> Stamped on Frame <input type="checkbox"/> Label <input type="checkbox"/> Other: _____
---	--

VIN/ENGINE NUMBER (IF MOTORCYCLE, MARK BOTH VIN AND ENG. BOXES)			
VIN ENG <input checked="" type="checkbox"/> Appears okay <input type="checkbox"/> Altered/Tampered	VIN ENG <input type="checkbox"/> Illegible/Damaged <input type="checkbox"/> Missing	VIN ENG <input type="checkbox"/> Cannot locate <input type="checkbox"/> None—Newly built	VIN ENG <input type="checkbox"/> Assigned by F/O <input type="checkbox"/> See REMARKS

FEDERAL CERTIFICATION LABEL (1970 AND SUBSEQUENT YEAR MODELS):		
<input checked="" type="checkbox"/> Agrees with VIN <input type="checkbox"/> Disagrees with VIN	<input type="checkbox"/> Illegible/Damaged <input type="checkbox"/> Missing	<input type="checkbox"/> None—NA <input type="checkbox"/> See REMARKS

<b>ODOMETER MILEAGE READING</b> record mileage exactly as shown on vehicle odometer	25,535.10	(no tenths) <input checked="" type="checkbox"/> miles <input type="checkbox"/> kilometers
--	-----------	---

SUPPORTING DOCUMENTS: <input type="checkbox"/> Agrees with VIN <input type="checkbox"/> Disagrees with VIN	<input type="checkbox"/> No VIN on documents <input checked="" type="checkbox"/> None	<input type="checkbox"/> See REMARKS
--	--	--------------------------------------

EMISSION LABEL INDICATES:	
<input type="checkbox"/> Vehicle meets US EPA standards only <input type="checkbox"/> Vehicle meets US EPA standards and California standards <input type="checkbox"/> Vehicle meets California ULEV/ILEV Standards	<input type="checkbox"/> Vehicle meets California standards only <input type="checkbox"/> See REMARKS N/A

REMARKS <input type="checkbox"/> DO NOT PROCESS - REFER TO CHP
---

**I certify under penalty of perjury under the laws of the State of California that I examined the vehicle described above and I find the description of the vehicle to be as indicated.**

VERIFIER (PRINT NAME) RICHARD BIANCHI	TITLE/BADGE/ID NUMBER LRE 23
ADDRESS Department of Motor Vehicles 715 J Southpoint Blvd. Petaluma, CA 94954	CITY STATE

VERIFIED AT <input checked="" type="checkbox"/> Above address <input type="checkbox"/> Other (specify)	CITY STATE
--	------------

VERIFIER'S SIGNATURE X [Signature]	DATE 4-10-01
---------------------------------------	-----------------

VERIFYING AGENCY <input checked="" type="checkbox"/> DMV <input type="checkbox"/> Vehicle Verifier <input type="checkbox"/> Auto Club <input type="checkbox"/> Peace Officer (specify):
--

**STATEMENT OF FACTS — IDENTIFICATION NUMBER OR ENGINE NUMBER ERROR**  
**I certify under penalty of perjury that I am the owner of above described vehicle and had no knowledge of the difference in the identification or engine number on the vehicle and titling documents.**

VEHICLE OWNER'S SIGNATURE	DATE
---------------------------	------



V639868

# APPLICATION FOR TITLE OR REGISTRATION

DMV USE ONLY	
O/S DL #/STATE	
TECH INITIALS	

VEHICLE/HULL IDENTIFICATION NUMBER <b>ZFFPR 48B000102248</b>	MAKE OF VEHICLE OR VESSEL BUILDER <b>FERRARI 355</b>
---	---

800 634 APR 10 2001 25 0020 776

### 1. OWNER INFORMATION (Please print true full name or lessor/business name)

LAST NAME OR LESSOR OR BUSINESS NAME	FIRST NAME	MIDDLE NAME	CALIFORNIA DRIVER LICENSE OR ID NUMBER	
LAST NAME, OR LESSEE	FIRST NAME	MIDDLE NAME	CALIFORNIA DRIVER LICENSE OR ID NUMBER	
LAST NAME, OR LESSEE <input type="checkbox"/> AND <input type="checkbox"/> OR	FIRST NAME	MIDDLE NAME	CALIFORNIA DRIVER LICENSE OR ID NUMBER	
RESIDENCE OR BUSINESS ADDRESS (Include St., Ave., etc.)	APT./SPACE NO.	CITY	STATE	ZIP CODE
MAILING ADDRESS (If Different From Above)	APT./SPACE NO.	CITY	STATE	ZIP CODE
LESSEE ADDRESS (If Different From Above)	APT./SPACE NO.	CITY	STATE	ZIP CODE
ADDRESS WHERE TRAILER IS LOCATED (If Different From Above)		CITY	STATE	ZIP CODE

### 2. TITLE HOLDER INFORMATION (Do NOT reenter owners name) If "NONE", so print

NAME OF BANK/FINANCE COMPANY OR INDIVIDUAL <b>NONE</b>	ELECTRONIC TITLE NUMBER
BUSINESS OR RESIDENCE ADDRESS	APT./SPACE NO. CITY STATE ZIP CODE
MAILING ADDRESS (If Different From Above)	APT./SPACE NO. CITY STATE ZIP CODE

### 3. COST AND OPERATION INFORMATION (Purchase price does not include sales tax, insurance, finance charges, or warranty.)

MILES/KILOMETERS AT TIME OF ENTRY  
 1251,000 (no tenths)  Miles  Kilo.  is the actual mileage  is not the actual mileage  mileage exceeds the odometer mechanical limit

DATE VEHICLE ENTERED CALIFORNIA Mo. <u>March</u> Day <u>24</u> Yr. <u>2001</u>	PURCHASE PRICE OR MARKET VALUE (IF GIFT, OR TRADE) <u>\$62,061</u>
DATE YOU PURCHASED OR ACQUIRED VEHICLE Mo. <u>August</u> Day <u>31</u> Yr. <u>2000</u>	DATE YOU WENT TO WORK IN CALIFORNIA OR BECAME A RESIDENT Mo. _____ Day _____ Yr. <u>1982</u> (whichever occurred first)

- A. Will this vehicle be used to carry people for hire (taxi, bus, etc.)?  Yes  No
  - B. Are you now or have you within the last three years been on active duty with the U.S. Armed Forces?  Yes  No
  - C. When you acquired this vehicle were you on active duty in the U.S. Armed Forces?  Yes  No
- If yes, print name of state or country where stationed \_\_\_\_\_

### 4. OWNER(S) SIGNATURE(S)

The registered owner mailing address is valid, existing, and an accurate mailing address. I consent to receive service of process at this mailing address pursuant to §1808.21 of the Vehicle Code.

**I certify under penalty of perjury under the laws of the State of California that the foregoing is true and correct.**

OWNER'S SIGNATURE <b>X</b>	DATE <u>4/10/2001</u>	DAYTIME TELEPHONE NUMBER ( ) - - - - 6
OWNER'S SIGNATURE <b>X</b>	DATE	DAYTIME TELEPHONE NUMBER ( )

DEPARTMENT OF MOTOR VEHICLES  
REGISTRATION OPERATIONS DIVISION  
P.O. BOX 942869  
SACRAMENTO, CA 94269-0001



July 2, 2001

FILE - DI

AYNE  
SONOMA CA 95476

LIC: V639868  
VEH: FERRA  
VIN: ZFFPR48B000102248  
X-REF

We are unable to process your application for registration at this time, as the following items are needed to complete the application:

- The last registration certificate issued from the country of Italy.

OR

- A Foreign Vehicle Bond for the current retail value of the vehicle, issued by a bonding company authorized to do business in California. The bond must protect the Department, any and all its officers and employees, as well as any subsequent purchaser for a period of three years.

Please return a copy of this letter with the requested items to the address listed above, attention of license # V639868.

If you have any questions, please call (916)657-6795.

Sincerely,

C Schlottman, Manager  
Technical Compliance Section  
Registration Processing Unit I  
CS :gs

07/19/01 Kathy Griffen.



**BAR #: AL-128876  
EPA # CAL-0001-68497  
19564 8th St E.  
SONOMA, CA 95476  
Phone: 415-331-4512**

SONOMA CA 95476 Home Phone: 71 :	<b>95 FERRARI F355 GTS</b> 28629 Mi. Lic: 4SYF939/CA V8Cyl 3.5 Eng Vin: ZFFPR48B000102248 Eq: Profile:
--	---

**Job01 Major Service**

**Labor: \$12,400.00**

Remove power plant with subframe from the vehicle for service  
 Performed major service as per factory recommendation.  
 Updated timing belts and accessory belts.  
 Updated cam covers and seals.  
 Updated cam tensioners, bearings and seals.  
 Updated water pump assembly.  
 Replaced thermostat assembly and seals.  
 Upgrade cooling lines with silicone style hoses.  
 Replaced spark plugs and seals.  
 Replaced air filter and cleaned intakes.  
 Replaced fuel filters.  
 Install power plant, service with driving fluids.  
 Removed and replaced shifter seals, during pre service inspection found that the gearbox was leaking through these seals.  
 Disassembled throttle linkage repaired throttle cable and pedal assembly.  
 Flushed and bleed cooling system.  
 Serviced with new oil and filter.  
 Serviced A/C System. Updated broken seals.  
 Serviced and bleed brake system.  
 Set up, test for proper operation.

181610	Timing Belt-S	2.0 @	164.92 =S	329.84
167464	Belt pulley-S	2.0 @	164.35 =S	328.70
114808	Seal ring-S	4.0 @	5.78 =S	23.12
176157	Cam Cover Gasket-S	1.0 @	32.93 =S	32.93
178156	Cam Cover Gasket-S	1.0 @	32.93 =S	32.93
163620	Cam Gasket-S	1.0 @	17.29 =S	17.29
163621	Cam Gasket-S	1.0 @	17.26 =S	17.26
149554	Seal Ring-S	8.0 @	5.68 =S	45.44
158349	Seal Ring-S	4.0 @	4.99 =S	19.96
163987	Seal Ring-S	4.0 @	45.38 =S	181.52
0169970448	SEAL RING-N	2.0 @	11.45 =S	22.90
140787	Cam End Gasket-S	2.0 @	18.20 =S	36.40
169483	Spark Plug-S	8.0 @	29.84 =S	238.72
186922	Fuel Filter-S	2.0 @	73.20 =S	146.40
151562	Air Filter-S	2.0 @	69.90 =S	139.80
130623	Oil Filter-S	1.0 @	42.20 =S	42.20
109671	Thermostat-S	1.0 @	137.58 =S	137.58

**Continued on the next page**

**BAR #: AL-128876  
EPA # CAL-0001-68497  
19564 8th St E.  
SONOMA, CA 95476  
Phone: 415-331-4512**

**Order Date 10/30/23 06:34 pm  
Paid: 12/12/23 05:55 pm**

**Job01 Major Service**

10510092	Seal Ring-S	1.0 @	38.20 =S	38.20
1010445	Seal Ring-S	1.0 @	7.20 =S	7.20
154546	Complete Coolant Pump-S	1.0 @	606.20 =S	606.20
158101	P/S Belt-S	1.0 @	26.20 =S	26.20
158102	Belt Alt-S	1.0 @	29.20 =S	29.20
156703	Belt Alternator-S	1.0 @	30.20 =S	30.20
187991	Coupling Accel Cable-S	1.0 @	45.20 =S	45.20
164417	Coolant Hose Silic-S	2.0 @	89.20 =S	178.40
64612000	Coolant Hose Silc-S	1.0 @	109.90 =S	109.90
145192	Seal Washer-S	8.0 @	6.20 =S	49.60
S17	RP MOTOR OIL-N	9.5 @	18.20 =S	172.90
S5	ANTIFREEZE-N	3.0 @	28.90 =S	86.70
S4	DOT 4-N	2.0 @	31.20 =S	62.40
98101001	Oring A/C-S	2.0 @	2.90 =S	5.80
149554	Spark Plug Seal-S	8.0 @	4.90 =S	39.20
FREON	FREON-N	2.0 @	24.20 =S	48.40
289299	A/C Gasket-S	1.0 @	41.20 =S	41.20
8281	Clamp Kit-S	1.0 @	30.00 =S	30.00
1290921	Hose-S	1.0 @	40.20 =S	40.20
S19	NS GEAR OIL-N	0.7 @	34.90 =S	24.43
ATF-DEX3	ATF OIL-N	1.0 @	8.95 =S	8.95
FUEL	FUEL-S	1.0 @	40.00 =S	40.00
200281	Service Hardwre Kit-S	1.0 @	14.21 =S	14.21
PC	PARTS CLEANER-N	1.5 @	9.95 =S	14.92
				<b>3542.60</b>

**Job02 Coating**

**Labor: \$545.00**

Blast clean, repair and powder coat valve covers and ignition wire plates.

**Job03 Test**

**Labor: \$200.00**

Performed setup and 2 tests.

**Payments to VALTELLINA AUTOMOBILI**

**Cost Summary**

Labor	13145.00
Parts	3,542.60
Haz Waste	8.00
Subtotal	16695.60
Tax	301.12

**Continued on the next page**

I hereby authorize the above repair work to be done with the necessary material and hereby grant you and/or your employees permission to operate the car, truck or vehicle herein described on street, highways or elsewhere for the purpose of testing and/or inspection. An express mechanics lien is hereby acknowledged on above car, truck or vehicle to secure the amount of repairs thereto. You will not be held responsible for loss or damage to vehicle or articles left in vehicle in case of fire, accident or any other cause beyond your control.

(Signature) \_\_\_\_\_

**VALTELLINA AUTOMOBILI**

**Invoice No.**  
**000005009**

BAR #: AL-128876  
EPA # CAL-0001-68497  
19564 8th St E.  
SONOMA, CA 95476  
Phone: 415-331-4512

Order Date 10/30/23 06:34 pm  
Paid: 12/12/23 05:55 pm

**Payments to VALTELLINA AUTOMOBILI**

**Cost Summary**

Total	\$16996.72
Payments	16996.72
Bal Due	0.00

**Status: Paid Work Order**

**Payments: \$16,996.72**  
**1 12/12/23 16996.72 Visa**

**Thank you for choosing VALTELLINA AUTOMOBILI**



**000005129****Order Date 08/15/24 11:14 pm****Completed: 08/16/24 11:51 pm**

**BAR #: AL-128876**  
**EPA # CAL-0001-68497**  
**19564 8th St E.**  
**SONOMA, CA 95476**  
**Phone: 415-331-4512**

**PAYNE, SILVANO**  
**800 Siesta Way**  
  
**SONOMA CA 95476**  
**Home Phone: 707-322-4802**  
**:**

**95 FERRARI F355 GTS**  
**28686 Mi.Last in 10/30/2023**  
**Lic: 4SYF939/CA V8Cyl 3.5 Eng**  
**Vin: ZFFPR48B000102248**  
**Eq:**  
**Profile:**

**Job01 Top****Labor: \$1,000.00**

Performed diagnostic check and troubleshoot the drivers seat that did not return to original position and interrupted the convertible top operation.

Found that the drivers seat potentiometer was out of the resistance specs causing the top and seat not to function.

Removed drivers seat from the vehicle and removed unit.

Sent out potentiometer for repair and reinforcement update. New part is \$690.00

Assembled and calibrated unit.

Tested for proper operation.

**Job02 Stereo and Brake****Labor: \$440.00**

Removed stereo from the vehicle, opened unit and set the stereo to open position as requested. Unit needs to be replaced to properly work. Currently unit is disconnected because if key is turned on it sends power to the stereo and will get stuck again.

Removed covers for the parking brake, removed contact switch and repaired. Note, plastic on the contact switch is degrading and should be replaced.

**Payments to VALTELLINA AUTOMOBILI****Cost Summary****Status: Completed Work Order****Payments:**

<b>Labor</b>	<b>1,440.00</b>
<b>Parts</b>	<b>0.00</b>
<b>Subtotal</b>	<b>1,440.00</b>
<b>Total</b>	<b>\$1,440.00</b>
<b>Payments</b>	<b>0.00</b>
<b>Bal Due</b>	<b>1,440.00</b>

**Thank you for choosing VALTELLINA AUTOMOBILI**

I hereby authorize the above repair work to be done with the necessary material and hereby grant you and/or your employees permission to operate the car, truck or vehicle herein described on street, highways or elsewhere for the purpose of testing and/or inspection. An express mechanics lien is hereby acknowledged on above car, truck or vehicle to secure the amount of repairs thereto. You will not be held responsible for loss or damage to vehicle or articles left in vehicle in case of fire, accident or any other cause beyond your control.

(Signature) \_\_\_\_\_